

UNCLASSIFIED

AD NUMBER

AD830393

LIMITATION CHANGES

TO:

Approved for public release; distribution is unlimited.

FROM:

Distribution authorized to U.S. Gov't. agencies and their contractors;  
Administrative/Operational Use; DEC 1963. Other requests shall be referred to Army Materiel Command, Alexandria, VA.

AUTHORITY

USAMC ltr, 22 Jul 1971

THIS PAGE IS UNCLASSIFIED

AMCP-706-343

710 24

AMC PAMF . . . . .

**AMCP 706-343**

THIS IS A REPRINT WITHOUT CHANGE OF ORDP 20-343

CY 4 US

# RESEARCH AND DEVELOPMENT OF MATERIEL

ENGINEERING DESIGN HANDBOOK

## CARRIAGES AND MOUNTS SERIES TOP CARRIAGES

REDSTONE SCIENTIFIC INFORMATION CENTER



5 0510 01016449 6



LOAN COPY ONLY - DO NOT DESTROY  
PROPERTY OF  
REDSTONE SCIENTIFIC INFORMATION CENTER  
3 APR 1973

HEADQUARTERS  
UNITED STATES ARMY MATERIEL COMMAND  
WASHINGTON, D. C. 20315

31 December 1963

AMCP 706-343, Top Carriages, forming part of the Carriages and Mounts Series of the Army Materiel Command Engineering Design Handbook Series, is published for the information and guidance of all concerned.

(AMCRD)

FOR THE COMMANDER:

OFFICIAL:

SELWYN D. SMITH, JR.  
Major General, USA  
Chief of Staff



R. Q. DAVIDSON  
Colonel, GS  
Chief, Administrative Office

DISTRIBUTION: Special

## **PREFACE**

This handbook on Top Carriages has been prepared as one of a series on Carriages and Mounts. It presents information on the fundamental operating principles and design of top carriages.

This handbook was prepared under the direction of the Ordnance Engineering Handbook Office, Duke University, under contract to the Office of Ordnance Research. Text and line illustrations were prepared by The Franklin Institute, Philadelphia, Pennsylvania, under subcontract to the Ordnance Engineering Handbook Office. Technical assistance was rendered by the Ordnance Weapons Command.

## TABLE OF CONTENTS

	<i>Page</i>
PREFACE .....	i
LIST OF ILLUSTRATIONS .....	iv
LIST OF SYMBOLS .....	v
I. INTRODUCTION	
A. General .....	1
B. Purpose .....	1
C. Functions .....	1
II. EQUIPMENT ASSOCIATED WITH TOP CARRIAGE	
A. Equilibrators .....	1
B. Elevating Mechanisms .....	2
C. Traversing Mechanisms .....	2
III. TRUNNION BEARINGS	
A. Function .....	2
B. Types of Bearing .....	2
C. Design Factors .....	2
IV. TRAVERSE BEARING	
A. Function .....	3
B. Types of Bearing .....	3
C. Design Factors .....	3
V. TYPES OF TRAVERSE .....	6
VI. TYPES OF TOP CARRIAGE	
A. Single Recoil Type .....	7
B. Double Recoil Type .....	7
VII. DESIGN PROCEDURES	
A. Design Schedule .....	8
B. Structure .....	9
C. Construction, General .....	9
D. Construction, Single Recoil Type .....	10
E. Construction, Double Recoil Type .....	10
F. Favorable Location of Operating Units .....	10
G. Maintenance .....	11
H. Manufacturing Procedures .....	11
I. Suggested Materials for Top Carriages .....	12

## TABLE OF CONTENTS (Concluded)

	<i>Page</i>
<b>VIII. LOAD ANALYSIS AND STRESS</b>	
A. Loading Conditions.....	12
B. Single Recoil Type.....	12
C. Double Recoil Type.....	15
<b>IX. SAMPLE PROBLEM I, SINGLE RECOIL TYPE</b>	
A. Load Analysis.....	18
B. Traverse Bearing.....	19
C. Trunnion Bearing.....	19
D. Stresses of Structure.....	19
E. Base Plate.....	21
F. Trunnion Cap Bolts.....	21
<b>X. SAMPLE PROBLEM II, DOUBLE RECOIL TYPE</b>	
A. Load Analysis.....	22
B. Side Frame Analysis.....	25
<b>GLOSSARY.....</b>	<b>28</b>
<b>REFERENCES.....</b>	<b>30</b>
<b>INDEX.....</b>	<b>31</b>

## LIST OF ILLUSTRATIONS

<i>Figure</i>		<i>Page</i>
1	Typical Top Carriage Structure .....	1
2	Trunnion Bearing (Antifriction Type) .....	2
3	Smooth Surface Thrust Bearing .....	3
4	Traversing Roller Assembly .....	4
5	Types of Distributed Load on Thrust Bearing .....	4
6	Triangular Load Distribution on Annular Segment .....	4
7	Loading Diagram of Circular Segment .....	5
8	Loading Diagram of Annular Segment .....	5
9	Uniform Load Distribution on Annular Sector .....	6
10	Top Carriage, Double Recoil Type .....	8
11	Top Carriage, Double Recoil Type, Transport Condition .....	8
12	Top Carriage Loads and Reactions, Type I .....	13
13	Top Carriage Loads and Reactions, Type II .....	13
14	Composite Loads and Typical Section of Top Carriage .....	14
15	Top Carriage Loads and Reactions, Double Recoil Type .....	15
16	Load Analysis of a Side Frame Panel .....	16
17	Stress Distribution of Panel .....	17
18	Stiffener Spacing Based on Column Analogy .....	17
19	Trunnion Cap Loading Diagram .....	22
20	Design Bending Moment of Side Frame .....	26

## LIST OF SYMBOLS

$a$	long length of stiffened panel	$R$	total reaction on bearing
$b$	short length of stiffened panel	$R'_F$	vertical reaction on front slide of bottom carriage
$CG$	center of gravity	$R_L$	lower reaction on bearing
$c$	end fixity coefficient; distance, neutral axis to outermost fiber	$R'_R$	vertical reaction on rear slide of bottom carriage
$d$	stiffener spacing	$R_U$	upper reaction on bearing
$E$	modulus of elasticity	$R_V$	vertical reaction on bearing
$F_A$	trunnion load parallel to gun bore	$R_g$	elevating gear load
$F_E$	equilibrator force	$R_i$	inner radius
$F_N$	trunnion load normal to gun bore	$R_o$	outer radius
$F_T$	trunnion load	$R_r$	rod pull of secondary recoil mechanism
$F_h$	general expression for a horizontal force	$r$	general expression for radius
$F_v$	general expression for a vertical force	$S_f$	factor of safety
$F_2$	inertia force of secondary recoiling mass	$T$	torsional moment
$H_B$	inertia force of bogie	$t$	web thickness
$H_E$	horizontal component of equilibrator force	$V$	maximum vertical shear
$H_T$	horizontal component of trunnion load	$V_E$	vertical component of equilibrator force
$H_g$	horizontal component of elevating gear load	$V_T$	vertical component of trunnion load
$H'_2$	inertia force of front part of bottom carriage due to secondary recoil	$V_g$	vertical component of elevating gear load
$H''_2$	inertia force of rear part of bottom carriage due to secondary recoil	$W_B$	weight of bogie
$h_w$	web depth of plate girder	$W_{TC}$	weight of top carriage
$I$	moment of inertia of section	$W_2$	weight of the secondary recoiling parts
$I_s$	moment of inertia of stiffener cross section	$W'_2$	weight of front end of top carriage
$K$	stress factor	$W''_2$	weight of rear part of top carriage
$k$	radius of gyration	$\bar{x}$	distance from load $CG$ to bearing diameter, general expression
$M$	moment	$\mu$	coefficient of friction
$M_R$	moment about bearing diameter	$\nu$	Poisson's ratio
$NA$	neutral axis	$\sigma$	general expression for stress
$p$	maximum bearing pressure	$\sigma_{br}$	bearing stress
$P_i$	maximum bearing pressure at inner bearing radius	$\sigma_{cr}$	crippling stress
		$\tau$	general expression for shear stress
		$\tau_a$	shear stress along neutral axis of a beam



# CARRIAGES AND MOUNTS SERIES

## TOP CARRIAGES\*

### I. INTRODUCTION

#### A. GENERAL

1. This is one of a series of handbooks on Carriages and Mounts. This handbook deals with the design of top carriages.

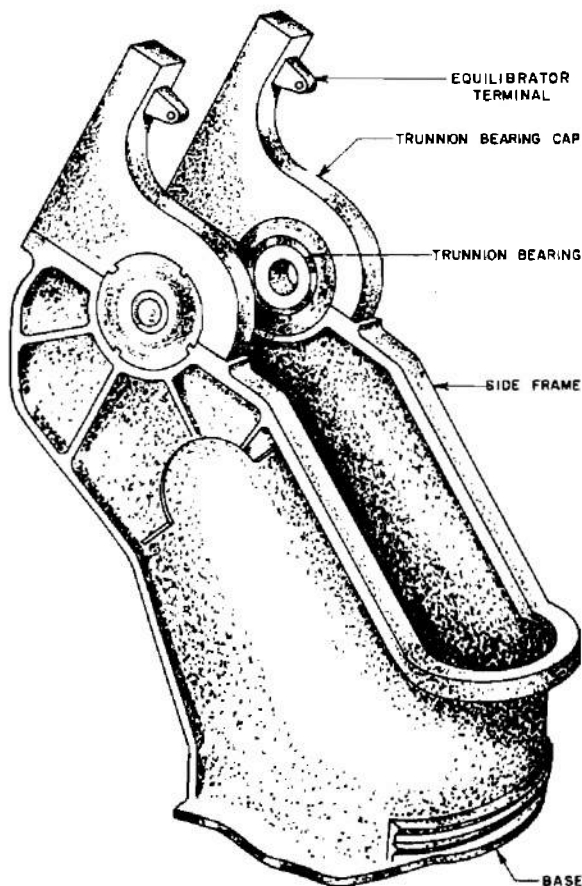

Figure 1. Typical Top Carriage Structure

#### B. PURPOSE

2. The top carriage was first introduced in Ordnance Corps Pamphlet ORDP 20-340† where it was discussed as one of the structures that make up a carriage or mount. This handbook deals specifically with the top carriage. It discusses the types of top carriage, their components, and their functions. It considers the requirements which each must meet and presents design data and procedures. Figure 1 shows a typical top carriage structure of a single recoil weapon.

#### C. FUNCTIONS

3. The top carriage is the primary supporting structure of the weapon. It supports the tipping parts through the trunnion bearings and transmits all firing loads from the cradle to the bottom carriage or other supporting structure. It anchors the equilibrators. It houses the elevating and traversing mechanisms and the power units needed for these mechanisms. In traverse, the top carriage moves with the cradle and, in double recoil systems, these two units constitute the bulk of the secondary recoiling mass.

### II. EQUIPMENT ASSOCIATED WITH TOP CARRIAGE

#### A. EQUILIBRATORS

4. The equilibrators are more directly associated with the cradle because their function is to balance the tipping parts but their terminals on the top carriage are considered to be parts of the latter. The terminals are fixed structures, bolted or welded to the side frames.

† Reference 1. References are found at the end of this handbook.

\* Prepared by Martin Regina, Laboratories for Research and Development of The Franklin Institute.

Each holds the pin or bearing about which one equilibrator pivots.

#### B. ELEVATING MECHANISMS

5. Except for the elevating arc which is attached to the cradle, the top carriage houses all components of the elevating mechanism. These include the pinion, the rest of the elevating gear train, the handwheel, and the power unit if one is necessary.

#### C. TRAVERSING MECHANISMS

6. The top carriage also houses part of the traversing mechanism. If the traversing rack is on the bottom carriage, the rest of the mechanism, including gear train and handwheel, is attached to the top carriage. If the rack is on the top carriage, these same components are attached to the bottom carriage.

### III. TRUNNION BEARINGS

#### A. FUNCTION

7. The trunnion bearings provide the low friction rotating elements which are so essential during elevation. They also transmit the firing loads from the cradle to the top carriage.

#### B. TYPES OF BEARING

8. Either journal or roller bearings are used. Roller bearings offer two advantages: lower frictional properties and adaptability to self alignment. Their high cost and comparatively large size requiring housings materially larger than those necessary for a sleeve bearing are the main disadvantages. On the other hand, journal bearings are smaller and cost less, but in this type of installation they do not have the low frictional properties associated with roller bearings.

#### C. DESIGN FACTORS

9. Structurally speaking, the trunnion bearings must be strong enough to support the large firing loads and still permit the trunnions to rotate freely as the weapon is elevated (Fig-

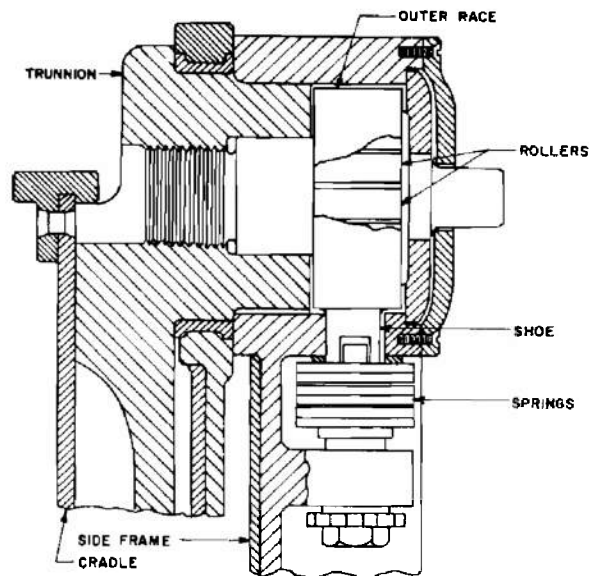

Figure 2. Trunnion Bearing (Antifriction Type)

ure 2). Whether of ball or roller type, each is selected according to manufacturers' specifications. Before the advent of high strength bearings, the tipping parts were supported by springs which lifted the trunnions off their seats, thus permitting the weight to rest solely on the bearings. But, during firing, recoil forces compressed the springs until the trunnions became seated on the rigid side frames thus relieving the bearings of these tremendous loads. Now that the load carrying capacity of ball and roller bearings are large, special measures to relieve them of firing loads are seldom necessary.

10. Bearings with rolling elements have a basic static load rating defined as the maximum static load which will show, at any one contact point, a combined permanent deformation of ring and rolling element of less than 0.0001 rolling element diameter.\* Ordinarily this deformation is not objectionable to the bearing when either at rest or running at high speed. If the rated static load is exceeded, minute depressions are formed in the raceways causing noise and vibration during subsequent operation. Sometimes the static load rating can be greatly exceeded without deleterious effects. In this respect, the rating may be doubled for

\* Reference 2, page 12.

trunnion and traverse bearings without impairing weapon accuracy. It is advisable to consult bearing authorities before the final selection, particularly if any design feature remains questionable.

11. Journal bearings are designed according to the strength of the material. The bearing stress is

$$\sigma_{br} = \frac{F_T}{A_{br}} \quad (1)$$

where  $F_T$  = trunnion load  
 $A_{br}$  = projected area of trunnion

For firing, when trunnions are not turning, the bearing stress should show a factor of safety,  $S_f$ , of 2.5. When the trunnions are turning, the bearing pressure should not exceed 300 psi.

#### IV. TRAVERSE BEARING

##### A. FUNCTION

12. The traverse bearing provides a low-frictional means for rotating the traversing parts. It incorporates both radial and thrust features. The radial component supports the weapon laterally through its pintle or stanchion whereas the thrust component supports its weight. Firing loads are transmitted through the bearing to the bottom carriages although in some weapons the vertical components of these loads travel directly from top to bottom carriage. The radial unit transmits the horizontal while the thrust unit transmits the vertical components of the loads.

##### B. TYPES OF BEARING

13. The traverse bearing may be either a sliding contact or a rolling contact type. The former is used where running loads are small and therefore frictional resistance is inherently low. Such is the radial component for side loads which are not appreciable during traverse. If firing loads are present during traverse, ball or roller radial bearings may be better suited. The thrust element is considered similarly, although the weight of the traversing parts contributes largely to the total bearing load. The bearing may be a complete annu-

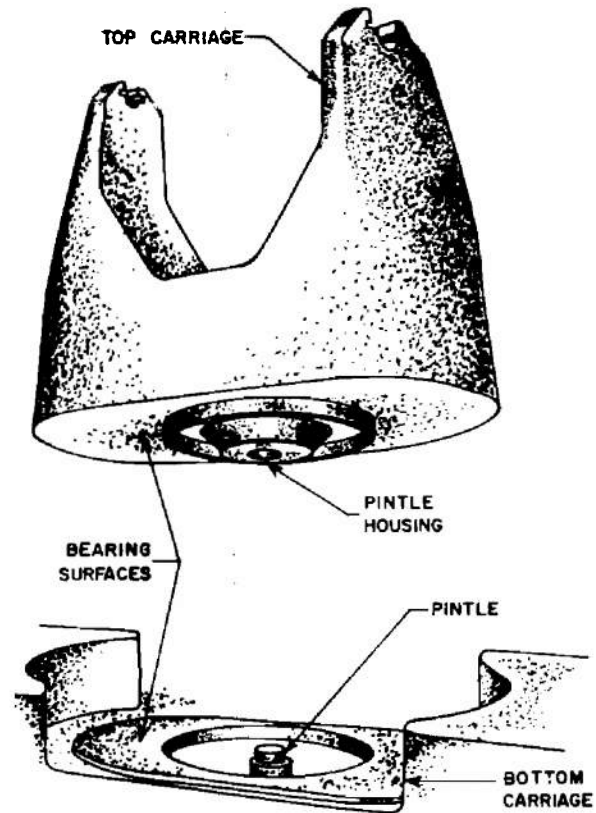

Figure 3. Smooth Surface Thrust Bearing

lus or it may be only a sector of an annulus. It may be a ball or roller bearing or it may be made of smooth machined surfaces as shown in Figure 3. Some medium and heavy artillery have thrust bearings supported by springs, usually Belleville, which are only stiff enough to carry the weight. Firing loads compress the springs and force top and bottom carriages into direct contact, thus relieving the rolling elements. Figure 4 illustrates this type.

##### C. DESIGN FACTORS

14. The design criteria of traverse bearings are similar to those for trunnion bearings. Bearing pressures between sliding surfaces should not exceed 300 psi during rotation. If the rotating parts are motionless, this pressure may increase to 40 percent of the strength of the material in the bearing without causing damage. Loads on ball or roller bearings should not exceed manufacturers' limits.

15. Thrust loads not uniformly distributed

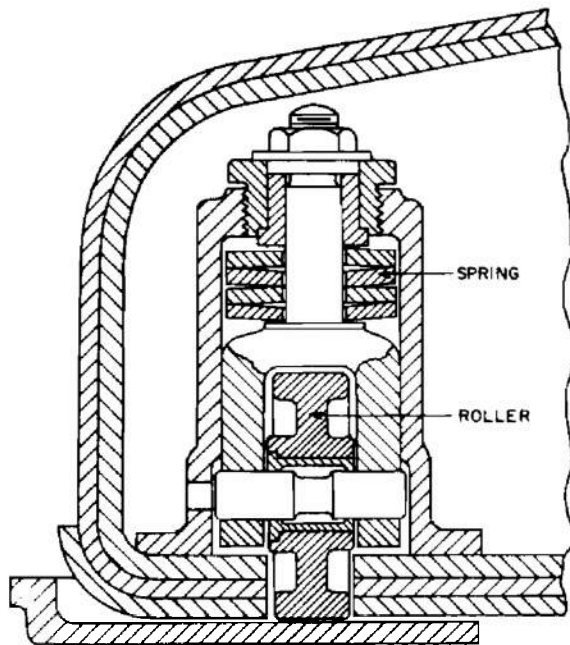

Figure 4. Traversing Roller Assembly

require a different approach in selecting a suitable bearing. This condition arises when the traverse bearing is the only link between top and bottom carriage. The bearing and its associated structure transmit all moments in addition to the direct loads. The moments occur during firing and are the products of rifling torque and the applied loads of the top carriage. In order to transmit the moments through the bearing, they are resolved into couples of horizontal or vertical forces, depending on the type of construction. If the bearing is divided as shown later in Figure 12, the moment is balanced by two horizontal reactions on the radial elements while the resultant vertical load reacts uniformly on the thrust element. The selection of bearings under this condition follows conventional procedures. If the bearing has only one radial element (refer to Figure 13), then the moment is balanced by a vertical force couple on the thrust interfaces while the horizontal reaction occurs radially. In this case, the selection of the radial bearing element is routine but as the thrust loads are not uniformly distributed, further analysis is indicated before selecting the thrust bearing elements.

16. If the thrust bearing is a complete an-

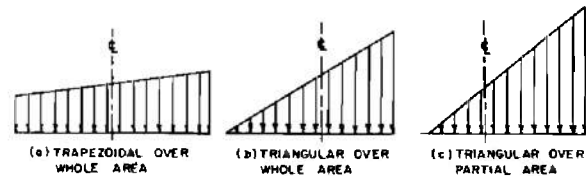

Figure 5. Types of Distributed Load on Thrust Bearing

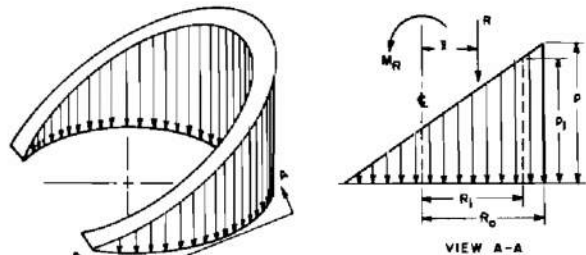

Figure 6. Triangular Load Distribution on Annular Segment

nulus, the load distribution probably will assume a shape similar to one of those in Figure 5. The trapezoidal distribution is optimistic and may prove troublesome by predicting bearing pressures much lower than those which eventually will develop. The triangular load distribution with its higher maximum pressure provides a more conservative approach. Its shape is that of a hollow unguia, similar to the one in Figure 6 where the volume represents the total bearing reaction. This leaves the extent of the pressure area still to be determined. The clearances between the bearing surfaces and their mating surfaces in the bottom carriage as well as the flexibility of the supporting structural members will have some effect on the load distribution. However, the structure itself is indeterminate, and with no solution readily available, any attempt to find the precise distribution may be impractical. Because of the flexibility of the structure, it is not likely that the load would be confined to less than half the bearing area. On the other hand, it may be just as unlikely that it will cover the total area. Retaining the conservative approach, the assumption that the load covers half the surface seems reasonable. Here the maximum pressure is about  $1\frac{1}{2}$  times the one where the whole area is involved. If conditions warrant, the pressure area may

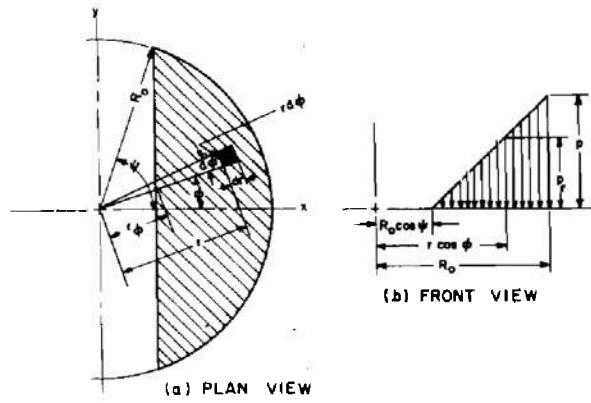

Figure 7. Loading Diagram of Circular Segment

be increased or decreased to suit the proposed structure.

17. In the general loading analysis for the triangular pressure distribution, assume the pressure area to be a circular segment as in Figure 7. The following nomenclature applies:

- $A$  = area
- $p$  = maximum bearing pressure
- $p_r$  = pressure at  $r$
- $r$  = radius
- $r_\phi$  = radius to chord of segment
- $R$  = total load (volume of ungula)
- $dR$  = differential load on  $dA$
- $R_o$  = outer radius of bearing
- $\phi$  = angular distance to  $dA$
- $\psi$  = limit of  $\phi$

Referring to Figure 7,

$$dA = r d\phi dr \quad (2)$$

$$dR = p_r dA = p_r r d\phi dr \quad (3)$$

From similar triangles we have

$$p_r = \frac{r \cos \phi - R_o \cos \psi}{R_o (1 - \cos \psi)} p \quad (4)$$

$$R = \frac{p}{R_o (1 - \cos \psi)} \int_{-\psi}^{\psi} \int_{r_\phi}^{R_o} (r \cos \phi - R_o \cos \psi) r dr d\phi \quad (5)$$

where the limits of  $r$  at  $\phi$  are  $R_o$  and  $r_\phi$ . But

$$r_\phi = R_o \frac{\cos \psi}{\cos \phi} \quad (5a)$$

After integration, the total load becomes

$$R = \frac{pR_o^2}{1 - \cos \psi} \left( \sin \psi - \psi \cos \psi - \frac{1}{3} \sin^3 \psi \right) \quad (6)$$

The moment of the load about the diameter is simply

$$M_R = R\bar{x} \quad (7)$$

Expressed as a differential

$$dM_R = x dR \quad (8)$$

$$\text{but } x = r \cos \phi \quad (8a)$$

Substituting for  $x$ ,  $dR$  (Equation 3) and  $p_r$  (Equation 4) and rewriting Equation 8

$$M_R = \frac{p}{R_o (1 - \cos \psi)} \int_{-\psi}^{\psi} \int_{R_o}^{R_o} \frac{\cos \psi}{\cos \phi} (r \cos \phi - R_o \cos \psi) r^2 \cos \phi dr d\phi \quad (9)$$

Integrating

$$M_R = \frac{pR_o^3}{1 - \cos \psi} \left( \frac{1}{4} \psi - \frac{5}{12} \cos \psi \sin \psi + \frac{1}{6} \cos^3 \psi \sin \psi \right) \quad (10)$$

18. When the thrust bearing is an annulus, the pressure area becomes a segment of an annulus instead of a segment of a circle. The equations for the total load and moment are derived by superposition.

In Figure 8,  $p_i$  is the maximum pressure at  $R_i$  where  $R_i$  is the inner radius of bearing. From similar triangles

$$p_i = p \frac{R_i}{R_o} \frac{1 - \cos \psi_i}{1 - \cos \psi} \quad (11)$$

By subtracting the values obtained from Equations 6 and 10 for the inner chord from

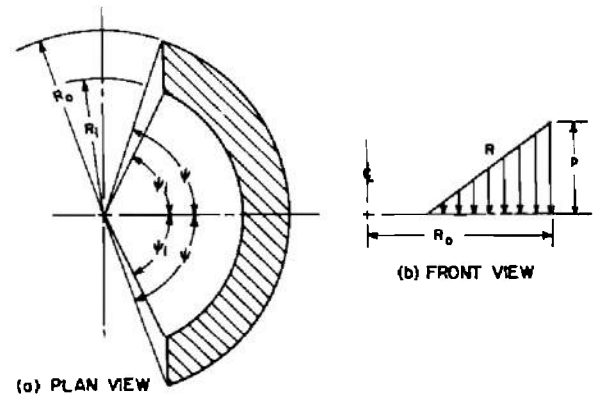

Figure 8. Loading Diagram of Annular Segment

those obtained for the total volume, load and moment become, respectively

$$R = \frac{pR_o^2}{1 - \cos \psi} \left( \sin \psi - \psi \cos \psi - \frac{1}{3} \sin^3 \psi \right) - \frac{p_i R_i^2}{1 - \cos \psi_i} \left( \sin \psi_i - \psi_i \cos \psi_i - \frac{1}{3} \sin^3 \psi_i \right) \quad (12)$$

and

$$M_R = \frac{pR_o^3}{1 - \cos \psi} \left( \frac{1}{4} \psi - \frac{5}{12} \cos \psi \sin \psi + \frac{1}{6} \cos^3 \psi \sin \psi \right) - \frac{p_i R_i^3}{1 - \cos \psi_i} \left( \frac{1}{4} \psi_i - \frac{5}{12} \cos \psi_i \sin \psi_i + \frac{1}{6} \cos^3 \psi_i \sin \psi_i \right) \quad (13)$$

The distance,  $\bar{x}$ , from the load center to the diameter is obtained by dividing Equation 12 into Equation 13 (see Equation 7). Previously (in Paragraph 16) a pressure area covering half the bearing surface was considered to be a reasonable estimate. When so applied, Equation 12 reduces to

$$R = \frac{2}{3} \frac{p}{R_o} (R_o^3 - R_i^3) \quad (14)$$

Equation 13 reduces to

$$M_R = \frac{\pi}{8} \frac{p}{R_o} (R_o^4 - R_i^4) \quad (15)$$

and  $\bar{x}$ , becomes

$$\bar{x}_s = \frac{3}{16} \pi \frac{R_o^4 - R_i^4}{R_o^3 - R_i^3} \quad (16)$$

The dimension,  $\bar{x}_s$ , completes the geometry of the loading system and  $R$  becomes readily available by balancing the force system. Finally  $p$  is found from Equation 14. This pressure, when applied over the whole bearing surface, establishes the equivalent bearing design load. It should be noted that Equations 12 through 16 are not valid when  $R_o \cos \psi > R_i \cos \psi_i$ . After  $\psi_i$  reaches 180 degrees, it is reasonable to assume that the whole annular area is subjected to the triangular load distribution. In this case

$$R = \frac{\pi}{2} p (R_o^2 - R_i^2) \quad (17)$$

$$M_R = \frac{\pi}{8} \frac{p}{R_o} (R_o^4 - R_i^4) \quad (18)$$

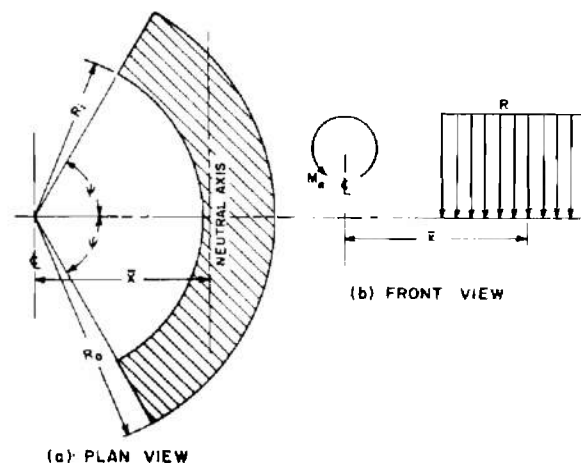

Figure 9. Uniform Load Distribution on Annular Sector

$$\bar{x}_a = \frac{1}{4} \frac{R_o^2 + R_i^2}{R_o} \quad (19)$$

Coincidentally, the moment about the diameter (Equation 18) is identical to that where half the annulus is loaded (Equation 15).

19. When the thrust bearing forms only a sector of the annulus, the load may be assumed to be distributed uniformly over the total area of the sector without serious error. The center of pressure is measured from the bearing axis to the neutral axis of the pressure area. From Figure 9

$$\bar{x}_b = \frac{2 \sin \psi}{3 \psi} \frac{R_o^3 - R_i^3}{R_o^2 - R_i^2} \quad (20)$$

where  $R_o$  = outer radius

$R_i$  = inner radius

$\psi$  = one half the sector angle

To simulate an annular thrust bearing, the designer arrives at some concept of size of the rolling contact bearing components by assuming that the uniform load extends completely around the periphery. However, as with other types of bearing, the advice of bearing manufacturers should be sought before making the final selection.

## V. TYPES OF TRAVERSE

20. The top carriage, as the primary supporting structure of the weapon, and the tipping parts traverse as a unit. There are several methods by which a weapon traverses depending on the type of top carriage. The

methods fall under two general groups, limited and unlimited. Unlimited traverse permits the weapon to train in azimuth through 360 degrees in either direction. Limited traverse restricts training to small angles, usually no more than 30 degrees on either side of the normal position.

21. The crudest attempt at unlimited traverse involves training the weapon in the general direction during emplacement. All guns, each time they are emplaced, can be so trained. But in the true sense, this cannot be termed traversing. Some guns are traversed 360 degrees by simply lifting one end of the carriage with jacks and pushing it around with available personnel. Weapons on vehicles are traversed in a complete arc by turning the vehicles. These methods provide only rough training in azimuth. The real advantage of these types is that the general direction is obtained quickly. The precise azimuth control is readily available with the traversing mechanism.

## VI. TYPES OF TOP CARRIAGE

22. Top carriages are of two types: single recoil and double recoil.

### A. SINGLE RECOIL TYPE

23. The top carriage for a single recoil weapon is a simple structure consisting basically of two side frames supported by a base plate (see Figure 1). It is supported by the bottom carriage or equivalent structure. It has no motion other than traversing. Whatever complexity the structure ultimately acquires is primarily due to the provision of convenient and adequate attachments for the mechanisms which it supports.

24. Trunnion bearings, equilibrators and parts of the elevating and traversing mechanisms are assembled to the side frames. For the sake of symmetry, the unit of two components such as trunnion bearings or twin equilibrators, has one attached to each side frame. If large loads are involved, a unit of one component should be centrally located. This applies to a single equilibrator and to the elevating pinion. Each is attached to the top

carriage by a shaft spanning the side frames. However, if a worm and worm gear segment replace the pinion and elevating gear, the worm is usually mounted on the base plate. The side frames provide a similar arrangement for the traversing mechanism.

25. The base plate, aside from supporting the side frames, supports the traverse bearing which turns about the pintle. The pintle fits in the bearing and transmits the horizontal force of the top carriage to the bottom carriage. The base plate also transmits the thrust or vertical load from top to bottom carriage. Its lower surface has a flat ring or racer which provides the required smooth bearing surface. This bearing surface may be machined directly on the top carriage or it may be a separate piece bolted to the base.

### B. DOUBLE RECOIL TYPE

26. While the top carriage of a single recoil weapon rotates with respect to the bottom carriage, that of a double recoil weapon also translates but only during the recoil cycle. Its chief asset stems from its role in the secondary recoil system which, in essence, is equivalent to a longer recoil stroke with a corresponding decrease in force. During recoil, the top carriage rails slide on four pads attached to the bottom carriage. The rails are the bottom chords of the side frames and are held on the pads by clips. All vertical loads are transmitted to the bottom carriage through the pads and clips. Except for the frictional forces on the sliding surfaces, all horizontal forces are transmitted to the bottom carriage by the secondary recoil mechanism.

27. The top carriage of the double recoil type, despite its name, is not restricted to double recoil guns. It may be used for single recoil weapons as well, providing all its inherent advantages except those derived from double recoil activity. The components of this top carriage have basically the same functions as their counterparts in the single recoil weapon. However, its size and shape and structural requirements differ materially (Figure 10). Transverse beams join the two side frames, serving a two-fold purpose by providing lateral stability and a means for attach-

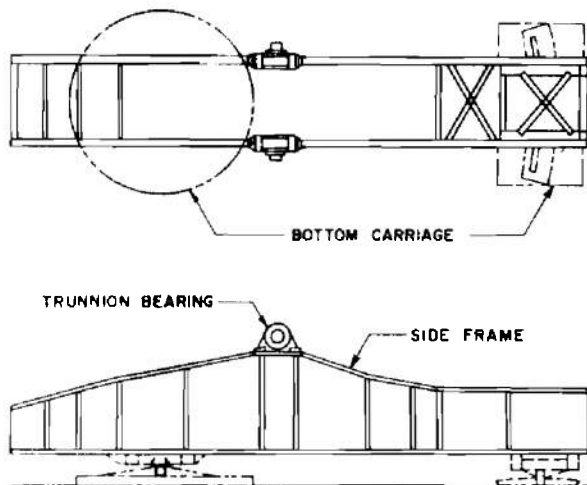

Figure 10. Top Carriage, Double Recoil Type

ing the operating equipment and structures generally associated with top carriages. These include parts of the elevating and traversing mechanisms, power equipment, and loading troughs. Sometimes a shaft or its housing, such as the elevating pinion shaft, spans the side frames and serves in a secondary capacity as a transverse beam.

28. The transporting units comprising bogie and limber are attached to the side frames (Figure 11) and may be permanently attached and retractable during firing or they may be detachable. Either or both units are replaceable by prime movers. If only one prime mover is necessary, it is conceivable to have it permanently attached but as such it becomes a part of the secondary recoiling mass and must be designed for the recoil accelerations.

## VII. DESIGN PROCEDURES

### A. DESIGN SCHEDULE

29. The design schedule follows a series of steps that is almost self-determining. Functional requirements, rigidity and strength are three predominant design criteria. Rigidity is needed to insure good weapon accuracy particularly if fire control equipment is mounted on the side frames. Although strength and rigidity usually go hand in hand, the structure may be too flexible and a means must be devised for providing the necessary stiffness. For strength, the top carriage must carry the applied forces of recoil and transport. The functional requirements involve little more than deciding on the type of top carriage and selecting the best suited locations for the equipment and secondary structures.

Whether the weapon is to be a single or a double recoil type should be decided during the preliminary design stage. Reference 1 discusses an approach on how to reach this decision. The firing of projectiles or other types of missile is the primary function of a weapon, and the supporting structures, including the top carriage, should be designed accordingly. Since the largest forces usually occur during the recoil cycle, they form the basis of top carriage design. The double recoil weapons are exceptions because some parts may be more critically stressed during transport.

30. There are three interdependent design factors: recoil force, length of recoil, and trunnion height. Any of these may be used for a start. For example, assume that the maximum

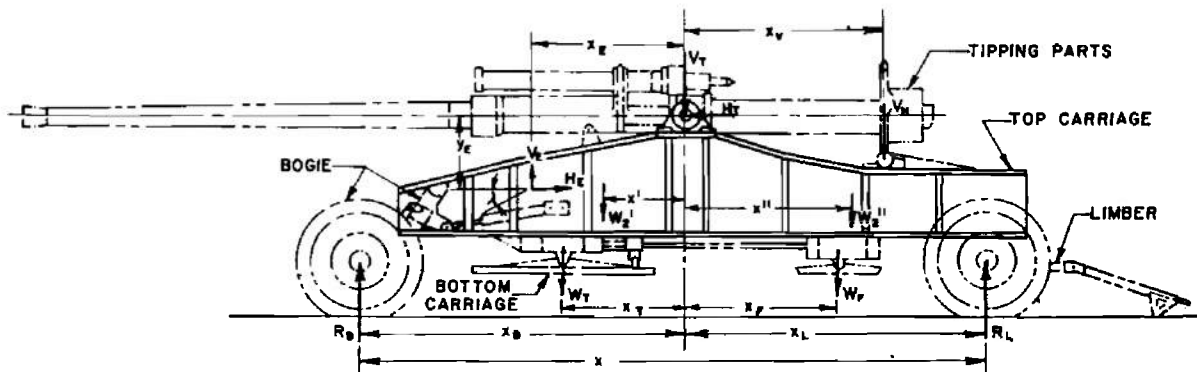

Figure 11. Top Carriage, Double Recoil Type, Transport Condition



height is given for a weapon in the horizontal firing position. This establishes the trunnion height which, together with the maximum angle of elevation, determines the recoil stroke. If longer recoil distances are desired, a pit must be dug for the necessary ground clearance. However, in present mobile mount design, this practice is discouraged. In another approach, the recoil distance may be selected and the recoil force and trunnion height determined from it.

31. For the early design stages, the preliminary recoil force is estimated according to the procedures given in Reference 3. This reference also has the method for determining buffing forces during counterrecoil. These forces, plus the weight, are instrumental in placing the ground reactions in those locations which will render the weapon stable during the recoil cycle. The first estimate of the weight is little better than a guess but, following preliminary estimates on loads and structural requirements, a more accurate estimate becomes available. The forces at three other locations are necessary to complete the external loading system of the top carriage. One is the load at the equilibrator attachment which is discussed in Reference 4. The other two are the elevating gear load and the trunnion loads treated in Reference 5 for both single and double recoil systems. If the top carriage is a double recoil type, its inertial forces resulting from secondary recoil accelerations must also be considered.

32. After all the external forces on the top carriage are known, the shear and moment diagrams are drawn for the firing condition. Shear and moment diagrams should also be prepared for the transport condition and compared with those of the firing condition. Usually, the allowable stresses for the two conditions differ but a comparison can be made by increasing the loads according to each respective load factor; the load factor being the desired factor of safety. For instance, assume that the factor of safety during firing is 1.5 and during transport is 3.0. To find the critical design condition, multiply each load during firing by 1.5 and during transport by 3.0. Now recompute the bending moments. A graph of these values will show the critical

condition at a glance. The stresses from these modified loads and moments require a factor of safety of 1.0.

33. Sufficient information is now available to design the basic structure. The concentrated loads of the equilibrator, elevating gear, and the like are also available to determine size and strength of the fittings and the local reinforcements to carry their loads into the top carriage. After the preliminary design is completed, a more accurate weight is computed and the preliminary design revised to conform with the new values.

#### B. STRUCTURE

34. The structure should be designed for simplicity, symmetry, and compactness. These qualities depend somewhat on each other. A simple structure is easy to fabricate and is usually a light and efficient one. A symmetrical structure also tends to maintain simplicity. Its load will be distributed more uniformly and eccentric loads which lead to heavy reinforcements are avoided. A compact structure is likely to reduce weight. In other words every effort should be made to find favorable locations for all structural members and equipment.

#### C. CONSTRUCTION, GENERAL

35. Top carriages are usually made of steel but other materials should not be excluded if they meet required physical properties. Use castings if weight is not a critical factor. They can have large fillets, thus eliminating harmful stress concentrations at re-entrant angles. Use forgings if high strength-weight ratios are needed. Weldments make reliable structures and are probably the least expensive. The built-up unit is relatively simple and light. Its joints are permanent and more rigid than if bolted or riveted. Weldments can be made from available stock and construction takes only a short time; these are reasons for their low cost. They can also be made of combined castings and mill stock. Although forgings and castings are not as susceptible to warpage as weldments, all should be stress relieved through heat treatment to insure dimensional stability.

36. Fittings and brackets for attaching equipment should be located near flanges and stiffeners. Local reinforcements at these fittings will carry and distribute their loads to the rigid structural members. For strength and efficiency, welded joints are recommended between fitting and carriage if disassembly is not essential. Additional reinforcements should be made where necessary to provide the torsional strength which is needed to support unsymmetrical loads during transport.

#### D. CONSTRUCTION, SINGLE RECOIL TYPE

37. The top carriage of the single recoil type is a compact structure whose members are readily constructed of forgings or castings or are fabricated by welding or riveting, welding being preferred. Regardless of the method of construction, the side frames are rigidly attached to the base plate. The base plate supports the traverse bearing. The racer of the bearing may be either integral with the base plate or, as a separate part, may be bolted to it. In some carriages, the base plate is replaced by a pintle housing which extends to the side frames. All sliding surfaces usually have a surface finish of 32 rms.

There are several ways of constructing the top carriage. Side frames and base may be forged or cast as one integral unit or the structure may be a weldment. Sometimes it may be convenient to construct all three separately and bolt the side frames to the base plate. Attachment fittings are constructed similarly. They may be a part of the general structure or fastened to it by some mechanical means. For example, the top of the side frames may be machined into trunnion bearing housings or they may be made into seats for the housing. Trunnion caps are bolted and keyed to the housings. Some structures have elongated caps to provide attachments for the equilibrators. Those with only one equilibrators have attachment lugs on the inner side of each side frame.

#### E. CONSTRUCTION, DOUBLE RECOIL TYPE

38. The top carriage of a double recoil weapon is a long structure not suitable for

castings and forgings. Therefore a structure made of built-up members such as trusses, plate girders, and box beams is appropriate. Weldments are preferred to riveted structures. The trunnion housings are also weldments which are keyed and bolted to the top of the side frames. Plate girders are recommended for the side frames for their efficiency and adaptability to the requirements of a weapon. Each side frame has a top and bottom chord, a web and stiffeners. The top chord is made of plate stock or it may be a box member while the bottom chord is made of plate stock. A portion of the latter is machined to a finish of 32 rms to serve as a sliding surface for the secondary recoiling parts. The top and bottom chords are joined by a web to form a somewhat elongated I-beam. Stiffeners spaced at intervals along the span carry the shear and prevent buckling of the web. Provided that they have the required sectional properties, stiffeners may have any shape, but channels with their open ends welded to the web are excellent for this purpose. Box beams traverse the structure and give it lateral stability. They are located conveniently at places where they can support auxiliary equipment.

#### F. FAVORABLE LOCATION OF OPERATING UNITS

39. The top carriage should be compact yet have room for various structural units and operating equipment. Clearance is the major criterion although ease of maintenance also should be considered when locating this equipment. Ground clearance determines the trunnion height and required clearance for the recoiling parts determines the space between the side frames. The problem now is to fit the operating units where they can function most effectively and where clearances will be ample either in this space or on the outer sides of the top carriage. These units include the equilibrators, the elevating unit, the traversing unit and loading devices. One favorable feature of the equilibrators is that if its geometry is maintained, it can occupy any position on the carriage without losing its effectiveness just so long as no interference exists between it and other units of the structure. On the other hand, the elevating and traversing

units, if possible, should be located between the side frames near the elevating arc and traversing gear. Handwheels are located near each other where they are readily accessible to, and easily operated by, the personnel. Power units should be located near their respective gears. Loading devices are attached to the rear of the side frames within easy access of the breech.

#### G. MAINTENANCE\*

40. The designer should be aware that the weapon he is creating can be manufactured in a relatively short time but its activity in the field can extend through many years. While in use, the weapon will be serviced and repaired often, many times under the stress of time and weather. It must be capable of ready partial disassembly in the field to remove malfunctioning controls, gear boxes, or shafts with a minimum of time and effort. Any necessity for removing serviceable items to reach the source of trouble not only wastes time and effort but also imposes additional problems of weather protection and realignment of these items. Assembly during manufacture is relatively easy due to sequential bench operations and readily available handling equipment. While in the design stage, equal consideration must be given to the orderly shop assembly program as well as to the field operation where only the damaged subassembly need be removed from the top carriage.

41. Preventive maintenance includes inspecting, cleaning, and lubricating. Inspection is the examination to detect structural failure or impending failure and to ascertain whether other maintenance steps are needed. Cleaning is necessary to remove dirt and other foreign matter which may prove harmful. A clean structure also has aesthetic value. Trunnion and traverse bearings must be sealed against dirt. Exposed sliding surfaces are kept clean by wipers. Pockets formed by structural members should have drain holes, otherwise accumulated water may later freeze to cause damage.

The need for a lubricant is obvious. A good

\* The subject of maintenance is covered in detail in Reference 6.

one is Spec MIL-G-10924A grease which lubricates effectively through a temperature range of  $-65^{\circ}$  to  $125^{\circ}$ F. Lubrication should be a simple task; therefore, fittings must be readily accessible. They should not be located in highly stressed regions of the top carriage because of the inherent stress concentration tendencies of small holes. If such locations are unavoidable, the holes should be heavily bossed for reinforcement. These preventive maintenance features should all be incorporated during design.

42. Corrective maintenance of the top carriage includes repair or replacement of its structural members including trunnion and traverse bearings. If the top carriage is weldable, failure in its primary structure can be repaired by welding, thus capitalizing on the advantage of weldable material. Other repairs involve moving parts such as turning or sliding surfaces. Damage to journal bearings or bearings with rolling elements invariably means replacement. Plain thrust bearings or the sliding surfaces of double recoil carriages can be repaired. Scored or galled surfaces are scraped and hand polished until smooth. If damage is too severe, they must be replaced. This emphasizes the need for good design practice with respect to maintenance. Those members of a structure which have a critical function and which are prone to damage should not be integral with the structure. Fundamentally, the key to ease of maintenance lies in the design of the top carriage inasmuch as this is the structure to which almost all weapon components are attached. Not only must adequate space be available, but their location on the top carriage must be readily accessible, a characteristic vital to both preventive and corrective maintenance.

#### H. MANUFACTURING PROCEDURES

43. Top carriages are manufactured by standard shop practices. If specialties are required, they exist in facilities rather than in fabrication techniques. Special facilities merely mean heat treating and machining equipment capable of handling bulky and irregular structures whose inherent weakness is not in the lack of strength but rather in the

difficulty of holding large dimensions to small tolerances. This is particularly true of structures that may warp during fabrication. However, the stress relieving of a properly restrained and supported structure will eliminate warpage to a large degree. Furthermore, if a structural member must have a finished surface, the practice of making it oversize is recommended. Then, those minor irregularities present after heat treatment can be removed as the member is being machined to size.

#### 1. SUGGESTED MATERIALS FOR TOP CARRIAGES

44. The structures of the top carriage have three requisites pertaining to physical properties, namely: strength, rigidity, and low weight. Weldability is a recommended fourth property. No material which meets these requirements should be excluded, but steel and aluminum are almost self-suggestive. Each has its advantages. Steel has a high modulus of elasticity and can have very high strength but steels of moderate strength are apt to be more appropriate because the resulting bulk is needed for rigidity. Steel, being sufficiently hard to impede scoring and compatible with bronze to impede galling, makes a good sliding surface. Aluminum alloys, having all the essential requirements, also are excellent structural material. Their strengths match those of moderate strength steels and they weigh only one-third as much.\* Their modulus is also lower, in about the same ratio, but aluminum alloys suffer in this respect as a similar steel structure has almost three times the rigidity. Added bulk would reduce the flexibility but at the expense of increased weight although its weight may still be less than a comparable steel structure. Aluminum is a notoriously poor sliding material but this deficiency can be overcome by covering its sliding surfaces with good bearing materials such as steel or hard bearing bronze. The designer must weigh the relative merits of all suitable materials and select the one which will culminate in the most efficient design.

\* Reference 7.

## VIII. LOAD ANALYSIS AND STRESS

### A. LOADING CONDITIONS

45. Two primary loading conditions prevail: firing and transport. There are as many firing conditions as there are angles of elevation but only the critical ones are investigated, usually the maximum, minimum and some intermediate angle of elevation. The loads imposed on the top carriage during counterrecoil must also be considered as part of the firing conditions. The transport conditions include normal travel, braking, and the 30 per cent side slope. The critical condition is found for the general structure by following the procedure discussed in Paragraph 32. In cases where individual parts or attachments are involved and the shear and moment diagrams do not consider them, the same method is followed, that is, multiply each load by its respective load factor and select the largest one as the critical condition. Since the 30 percent side slope condition involves only low transport speeds and this condition is not prevalent, it requires a load factor of only 1.0.

### B. SINGLE RECOIL TYPE

46. The forces applied to the top carriage including trunnion loads, equilibrator force, and elevating gear load, are found in Paragraphs 84 to 88 of Reference 5. These forces and the weight are shown in Figure 12. To simplify the loading analysis, resolve each force into components parallel and perpendicular to the carriage base as it rests on a horizontal plane. Thus

$$H_T = F_A \cos \theta + F_N \sin \theta \quad (21a)$$

$$V_T = F_A \sin \theta - F_N \cos \theta \quad (21b)$$

$$H_E = F_E \cos \lambda \quad (21c)$$

$$V_E = F_E \sin \lambda \quad (21d)$$

$$H_G = R_G \cos \rho \quad (21e)$$

$$V_G = R_G \sin \rho \quad (21f)$$

where  $F_A$  = trunnion load parallel to bore  
 $F_N$  = trunnion load normal to bore  
 $F_E$  = equilibrator force  
 $R_G$  = elevating gear load

47. The nature of the reactions on the base

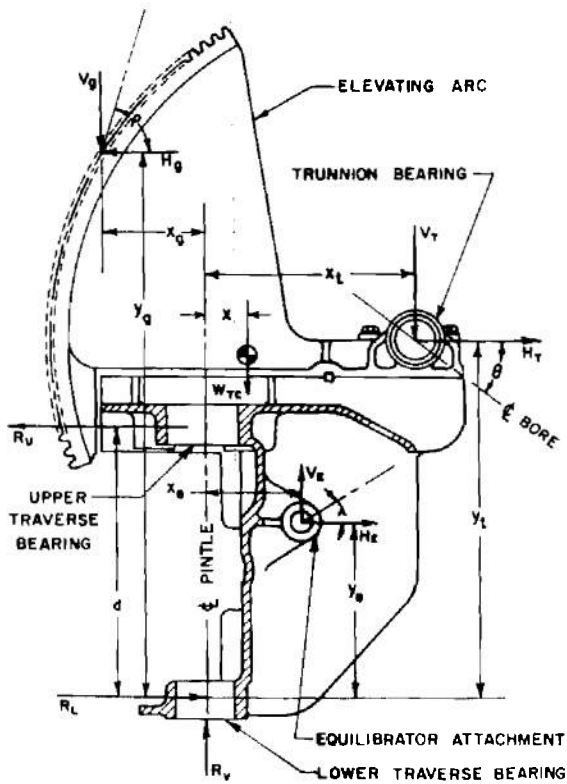

- $H_E$  = HORIZONTAL COMPONENT OF EQUILIBRATOR LOAD
- $V_E$  = VERTICAL COMPONENT OF EQUILIBRATOR LOAD
- $H_G$  = HORIZONTAL COMPONENT OF ELEVATING GEAR LOAD
- $V_G$  = VERTICAL COMPONENT OF ELEVATING GEAR LOAD
- $H_T$  = HORIZONTAL COMPONENT OF TRUNNION LOAD
- $V_T$  = VERTICAL COMPONENT OF TRUNNION LOAD
- $R_L$  = LOWER REACTION ON BEARING
- $R_U$  = UPPER REACTION ON BEARING
- $R_V$  = VERTICAL REACTION ON BEARING
- $W_{TC}$  = WEIGHT OF TOP CARRIAGE

Figure 12. Top Carriage Loads and Reactions, Type I

of the top carriage at the pintle and traverse bearing depends on the type of construction. If the moment reacts on the top and bottom pintle bearings as shown in Figure 12, the reactions include two horizontal and one vertical component. Take moments about the intersection of  $R_L$  and  $R_V$  and solve for  $R_U$ .

$$M = R_U d = x_L V_T - x_G V_G - x_E V_E + x W_{TC} + y_L H_T - y_G H_G + y_E H_E \quad (22)$$

where  $x$  and  $y$  are the respective horizontal and vertical moment arms and  $W_{TC}$  is the weight of the top carriage.

$$R_U = \frac{M}{d} \quad (23)$$

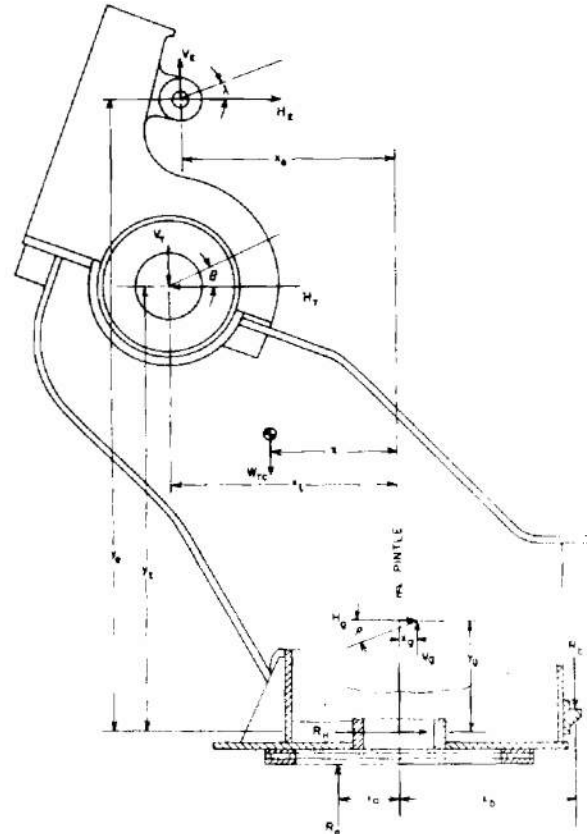

- $H_E$  = HORIZONTAL COMPONENT OF EQUILIBRATOR LOAD
- $V_E$  = VERTICAL COMPONENT OF EQUILIBRATOR LOAD
- $H_G$  = HORIZONTAL COMPONENT OF ELEVATING GEAR LOAD
- $V_G$  = VERTICAL COMPONENT OF ELEVATING GEAR LOAD
- $H_T$  = HORIZONTAL COMPONENT OF TRUNNION LOAD
- $V_T$  = VERTICAL COMPONENT OF TRUNNION LOAD
- $R_H$  = HORIZONTAL PINTLE REACTION
- $R_E$  = VERTICAL TRAVERSE BEARING REACTION
- $R_B$  = VERTICAL BEARING CLIP REACTION
- $W_{TC}$  = WEIGHT OF TOP CARRIAGE

Figure 13. Top Carriage Loads and Reactions, Type II

$$R_L = R_U + H_G - H_T - H_E \quad (24)$$

$$R_V = V_T + V_G - V_E + W_{TC} \quad (25)$$

If the moment is resisted by the thrust bearing and bearing clips or some similar device, then the reactions include two vertical and one horizontal component as shown in Figure 13 (refer to Paragraphs 18 and 19). Sometimes  $R_b$  reacts on the pintle. The reactions are found by taking moments about the intersection of  $R_H$  and  $R_b$  and solving for  $R_a$ .

48. The moment  $M_R$  of Equation 7 and the

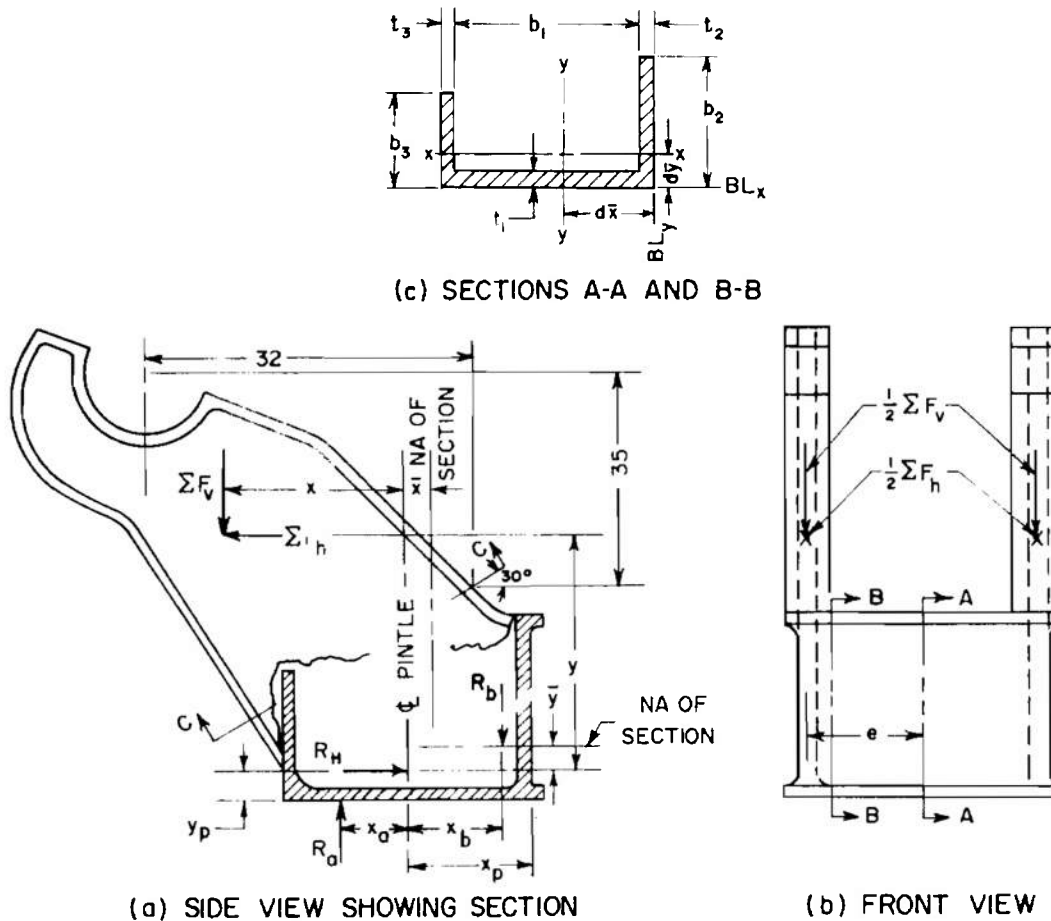

Figure 14. Composite Loads and Typical Section of Top Carriage

applied loads trace their way through the side frames and the base and eventually into the traverse bearing. The side frames are too short to be influenced by column action but must sustain direct bending and compressive stresses. The base is considered a transverse beam subjected to bending and to shear stresses caused by the torsional moment. For any particular section, the moment arm for all side frame loads is the distance from the section to the side frame (see dimension  $e$  of Figure 14b). The torsional moment arms are considered as the distances from the applied loads to the point of intersection of the horizontal and vertical neutral axes of the section when the point is projected into the side frame. Referring again to Figure 14b, the moment about the vertical neutral axis is the summa-

tion of the horizontal forces in a side frame times the moment arm  $e$ .

$$M_y = \frac{1}{2} e \Sigma F_h \quad (26)$$

The moment about the horizontal neutral axis is the summation of the vertical forces in a side frame times the same moment arm.

$$M_x = \frac{1}{2} e \Sigma F_v \quad (27)$$

The torsional moment is the summation of the individual torsional moments in a side frame.

$$T = \frac{1}{2} \Sigma (F_v x + F_h y) \quad (28)$$

49. It should be noted that as the distance increases from Section B-B toward Section A-A (Figure 14), at midspan the influence of reactions  $R_a$  and  $R_b$  reduces the torsional moment to zero as Section A-A is approached.

The maximum torsion is at Section *B-B*, adjacent to the side frame. The length of the base is too short to offer a true torsional stress picture hence, based on the principle of Saint-Venant, a statically equivalent system replaces the torsional moment.\* This method of analysis is illustrated in Sample Problem I.

### C. DOUBLE RECOIL TYPE

50. Before the loading analysis of the double recoil type is started, preliminary recoil forces must be estimated. Presumably these forces, since they depend somewhat on the weight of the top carriage, an unknown quantity at this stage, will change but they will be accurate enough for the first design attempt. The equation for calculating the inertia force,

\* Reference 8, Page 33.

$F_2$ , of the secondary recoiling parts appears in Reference 5. The trunnion loads are obtained from the same source. After the inertia force is calculated, all forces are available except the rod force on the secondary recoil mechanism and the frictional forces on the slides. However, the sum of these two forces equals the estimated secondary recoil force. The unknown forces are found by balancing the loading system shown in Figure 15.

51. Consider the weight of the top carriage as being concentrated at two points, the centers of gravity of the front and rear sections. Later, in a more detailed analysis, the weight will be distributed along the span. Resolve the trunnion, equilibrator, and elevating gear loads into their vertical and horizontal components. From statics

$$\Sigma F_v = 0$$

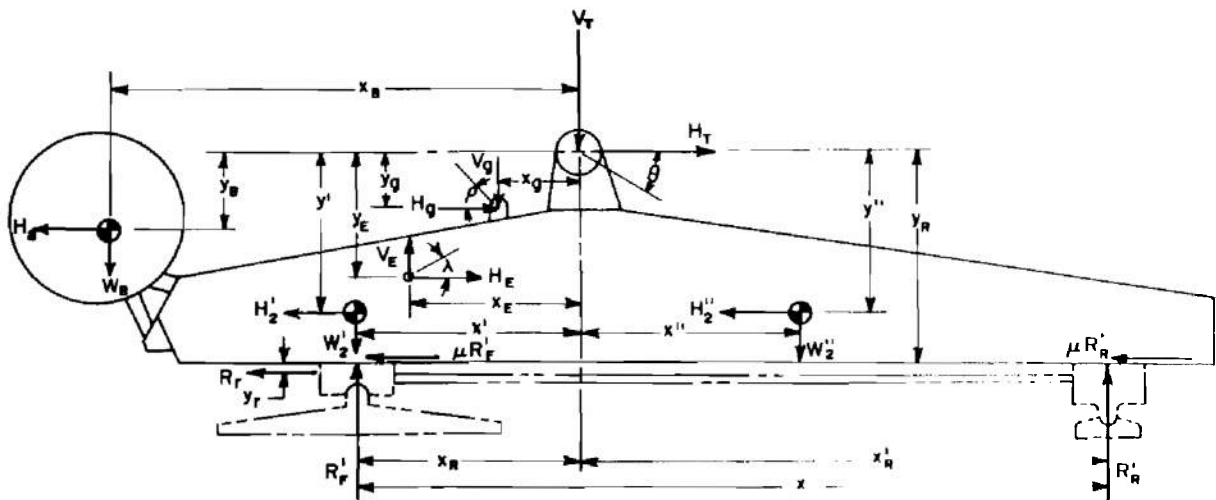

- $H_T, V_T$  = HORIZONTAL AND VERTICAL COMPONENTS OF TRUNNION LOAD  
 $H_2', H_2''$  = INERTIA FORCES DUE TO SECONDARY RECOIL ACCELERATION  
 $W_2', W_2''$  = WEIGHTS OF FRONT AND REAR TOP CARRIAGE STRUCTURE  
 $H_B, W_B$  = INERTIA FORCE AND WEIGHT OF BOGIE  
 $H_E, V_E$  = HORIZONTAL AND VERTICAL COMPONENTS OF EQUILIBRATOR LOAD  
 $H_G, V_G$  = HORIZONTAL AND VERTICAL COMPONENTS OF ELEVATING GEAR LOAD  
 $R_f'$  = VERTICAL REACTION ON FRONT SLIDE OF BOTTOM CARRIAGE  
 $R_r'$  = VERTICAL REACTION ON REAR SLIDE OF BOTTOM CARRIAGE  
 $R_r$  = ROD PULL OF SECONDARY RECOIL MECHANISM  
 $\mu R_f'$  = FRICTIONAL FORCE ON FRONT SLIDE OF BOTTOM CARRIAGE  
 $\mu R_r'$  = FRICTIONAL FORCE ON REAR SLIDE OF BOTTOM CARRIAGE

Figure 15. Top Carriage Loads and Reactions, Double Recoil Type

and

$$R'_F + R'_R = V_T + V_o - V_E + W'_2 + W''_2 + W_B \quad (29)$$

The total frictional force is

$$\mu R'_F + \mu R'_R = \mu(R'_F + R'_R) \quad (29a)$$

and the total secondary recoil resistance is

$$R = R_r + \mu(R'_F + R'_R) \quad (29b)$$

The coefficient of friction of the sliding surfaces is usually assumed to be 0.15. Again from statics

$$\Sigma F_h = 0$$

$$\text{or } R_r + \mu R'_F + \mu R'_R = H_T - H'_2 - H''_2 + H_E + H_o - H_B \quad (30)$$

Solving for  $R_r$ ,

$$R_r = H_T + H_o + H_E - F_2 - H_B - \mu(R'_F + R'_R) \quad (30a)$$

where  $F_2 = H'_2 + H''_2$ , the inertial force of the secondary recoiling mass. Since generally  $\Sigma M = 0$ ,  $R'_F$  is found by taking moments about the intersection of  $R'_R$  and  $\mu R'_R$ . Thus

$$xR'_F = \Sigma M' \quad (31a)$$

$$\text{or } R'_F = \frac{\Sigma M'}{x} \quad (31b)$$

where  $\Sigma M'$  is the summation of all the other moments about  $R'_R$ . It is now a matter of arithmetic to find  $R'_R$ ,  $\mu R'_F$  and  $\mu R'_R$ .

52. The next step is to find the shear and moment diagrams along the top carriage. To distribute the inertial forces more generally, the weights and corresponding inertia forces of the various concentrated masses are applied at their own centers of gravity. The remaining mass of the top carriage is distributed uniformly along its length. Divide the structure into a convenient number of stations, and identify each according to its distance from the trunnions; positive being toward the left. It is convenient to locate stations at concentrated loads. Uniform loads are assumed concentrated halfway between stations. Assume that each section is symmetrical about its neutral axis. The summation of shear loads and moments are found for each section, the moments being taken about the neutral axis. Clockwise moments, upward loads, and loads directed to the right are positive. Then according to Figure 16, which illustrates this

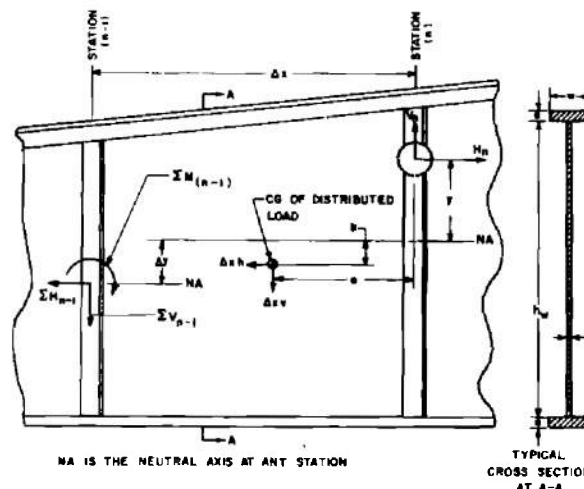

Figure 16. Load Analysis of a Side Frame Panel

arrangement for one panel, shears and moment at each station become

$$\Sigma V_n = \Sigma V_{n-1} + V_n + \Delta xv \quad (32)$$

$$\Sigma H_n = \Sigma H_{n-1} + H_n + \Delta xh \quad (33)$$

$$\Sigma M_n = \Sigma M_{n-1} + \Delta x \Sigma V_{n-1} + a \Delta xv + \Delta y \Sigma H_{n-1} + y H_n + b \Delta xh \quad (34)$$

where

$h$  = unit horizontal load between stations  
 $H_n$  = concentrated horizontal load at station

$\Sigma H_{n-1}$  = total horizontal load at station  $(n - 1)$   
 $\Sigma H_n$  = total horizontal load at immediate station

$\Sigma M_n$  = bending moment at station  
 $v$  = unit vertical load between stations  
 $V_n$  = concentrated vertical load at station  
 $\Sigma V_{n-1}$  = total vertical load at station  $(n - 1)$   
 $\Sigma V_n$  = total vertical load at immediate station

$a$  = moment arm for unit vertical load  
 $b$  = moment arm for unit horizontal load  
 $n$  = immediate station being considered  
 $\Delta x$  =  $n - (n - 1)$ , distance between stations

$y$  = moment arm for concentrated horizontal load

$\Delta y$  = distance between neutral axes of stations  $n$  and  $(n - 1)$

53. Shear loads and bending moments are found at the same stations for the transport conditions. Multiply all values by their re-



spective load factors: 1.5 for the firing conditions, 3.0 for the transport conditions. The maximum values thus obtained at any particular station, whether during firing or transport, become the basis of the design. Later, analyze the attachments and reinforcements for the applied local loads. After the first analysis available weight computations become more accurate which leads to more precise recoil data. Having recalculated the recoil forces, the analysis of the top carriage is revised accordingly. Although a later revision in design may mean a change in weight and a further change in recoil forces, the structure itself seldom needs alterations to carry the new loads.

54. The side frame is a beam having critical stresses in bending and in shear. The bending stress is simply

$$\sigma = \frac{Mc}{I} \quad (35)$$

and the shear stress, considering the web only, is

$$\tau = \frac{\Sigma V_n}{A_w} \quad (36)$$

where  $A_w$  is its cross sectional area. However, the shear stress as computed above may not be maximum because the shear along the neutral axis may be greater. Thus

$$\tau_a = \frac{V}{I t} A_a \bar{y} \quad (37)$$

where  $A_a$  = area above the neutral axis, in<sup>2</sup>  
 $I$  = moment of inertia, in<sup>4</sup>  
 $t$  = thickness of web, in  
 $V$  = vertical shear, lb  
 $\bar{y}$  = distance from the neutral axis to the centroid of  $A_a$

55. Buckling also should be considered for the side frames of double recoil type top carriages. Although the beam may be strong enough in bending and in shear, local failure by buckling of the web may occur. If so, vertical stiffeners will provide local rigidity. When shear stresses exist at any point in the cross section of a beam, tensile and compressive stresses occur simultaneously but in planes oblique to the cross section. At the neutral axis, where the direct bending stresses are zero, the planes of maximum tensile and compressive stresses are mutually perpendicular

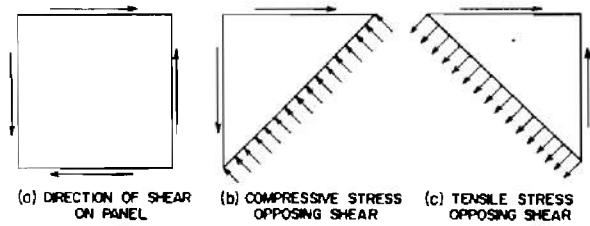

Figure 17. Stress Distribution of Panel

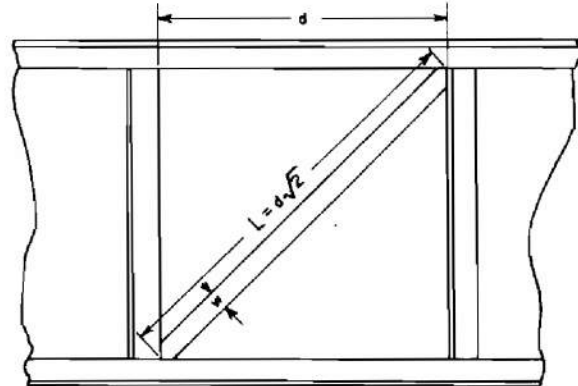

Figure 18. Stiffener Spacing Based on Column Analogy

and are inclined 45 degrees to the shear plane. Figure 17 illustrates these stress directions. It is the compressive stress which causes a web to buckle.

56. Consider a strip of unit width diagonally at 45 degrees between stiffeners such that the length according to Figure 18 is

$$L = d\sqrt{2} \quad (38)$$

where  $d$  is the distance between stiffeners.

Assume the strip to be a column and according to Euler, the crippling stress is

$$\sigma_{cr} = \frac{c\pi^2 E}{(L/k)^2} \quad (39)$$

where  $c$  is the end fixity coefficient.

If  $t$  is the web thickness and the width,  $w = 1$ , then

$$I = \frac{wt^3}{12} \quad (40)$$

$$A = wt \quad (40a)$$

$$k^2 = \frac{I}{A} = \frac{t^2}{12} \quad (40b)$$

$$\left(\frac{L}{k}\right)^2 = 24 \frac{d^2}{t^2} \quad (40c)$$

The edge restraint of the panel depends on bending and torsional rigidity of the stiffeners. High torsional rigidity is available in stiffeners having area enclosing cross sections such as tubes, hat sections and channels; the latter two have the open sides toward the panel to form the closed area. The end fixity coefficient of fully restrained columns is  $c = 4$ . However, since the flanges and stiffeners of the side frames restrain the ends of the assumed column, and since the tension field perpendicular to the compression field augments the restraint, a fixity coefficient much higher than  $c = 4$  is indicated. To be compatible with Equation 42, the coefficient should be increased to four times the restrained column fixity.

Referring to Figure 17, it is readily observed that, for the loads to balance, the intensity of the induced tensile stress must equal the intensity of the shear. Rewriting Equation 39 by inserting the indicated values for  $c$  and  $(L/k)^2$ , the crippling stress becomes

$$\sigma_{cr} = \tau_a = 6.58 \frac{Et^2}{d^2} \quad (41)$$

where  $\tau_a$  is the shear stress from Equation 37. Information is now available to solve for  $d$ , the required stiffener spacing. On the basis of the preceding discussion, if  $d$  is larger than the web depth, it will extend beyond the limits of the immediate stress field indicating that stiffeners are unnecessary.

57. The above method is approximate but becomes useful if more rigorous ones are unavailable. One of the latter has the crippling stress

$$\sigma_{cr} = K \frac{\pi^2 E}{12(1 - \nu^2)} \left(\frac{t}{b}\right)^2 \quad (42)$$

where

- $b$  = short length of stiffened panel
- $K$  = stress factor
- $t$  = web thickness
- $\nu$  = Poisson's ratio

The stress factor,  $K$ , of a rectangular plate is plotted for two conditions; one having the

\* Reference 9, Chapter B-2.3. Reprinted by permission from *Analysis and Design of Airplane Structures* by E. F. Bruhn, Copyright 1943, John S. Swift, Inc.

edges clamped, the other simply supported. Seeing that the panel of the plate girder lies between these two, it is suggested that  $K$  represent the median of the extremes.

58. A method for calculating the required moment of inertia of stiffeners is available in Reference 10. The equation based on this method is

$$I_s = \frac{d}{t} \left( \frac{Vh_w}{17.7E} \right)^{4/3} \quad (43)$$

- where  $d$  = stiffener spacing
- $h_w$  = web depth
- $I_s$  = moment of inertia of stiffener cross section
- $t$  = web thickness
- $V$  = maximum vertical shear

59. The contour of the stiffeners deserves some attention. Although only reinforcements, they should not appear as mere appendages but should contribute favorably to the general appearance of the structure. For example, stiffeners with sharp edges or stiffeners whose depth is greater than flange width should be avoided. Aside from the stiffener itself, the means of attachment to the web should be investigated. Welding is preferred to riveting because of the higher efficiency, but in either case the joint must be strong enough to carry the vertical shear.

## IX. SAMPLE PROBLEM I, SINGLE RECOIL TYPE

### A. LOAD ANALYSIS

60. This problem concerns a top carriage for a single recoil type weapon similar to Figure 13. The applied loads are obtained from the Sample Problem, U-Type Cradle, Reference 5.

- $F_E$  = 38,400 lb, equilibrator force
- $R_g$  = 5,800 lb, elevating gear load
- $F_A$  = 193,600 lb, trunnion load parallel to gun bore
- $F_N$  = 5,200 lb, trunnion load normal to gun bore
- $W_{TC}$  = 4,000 lb, weight of top carriage (assumed)

From the same reference

$$\begin{aligned}\lambda &= 45^\circ \\ \rho &= 90 - (\gamma + \beta) = 20^\circ \\ \theta &= 60^\circ\end{aligned}$$

From Equations 21a through 21f

$$\begin{aligned}H_T &= F_A \cos \theta + F_N \sin \theta \\ &= 96,800 + 4,500 = 101,300 \text{ lb}\end{aligned}$$

$$\begin{aligned}V_T &= F_A \sin \theta - F_N \cos \theta \\ &= 167,800 - 2,600 = 165,200 \text{ lb}\end{aligned}$$

$$H_E = F_E \cos \lambda = 27,200 \text{ lb}$$

$$V_E = F_E \sin \lambda = 27,200 \text{ lb}$$

$$H_g = R_g \cos \rho = 5,500 \text{ lb}$$

$$V_g = R_g \sin \rho = 2,000 \text{ lb}$$

In Figure 13 assign the following lengths (inches)

$$\begin{aligned}x_t &= 21.5 & y_t &= 42.5 \\ x_e &= 21.5 & y_e &= 59.5 \\ x_g &= 2.36 & y_g &= 14.9 \\ x &= 10.0\end{aligned}$$

The bearing surface of  $R_b$  consists of a  $120^\circ$  annular section. From Equation 20

$$\bar{x}_b = \frac{2 \sin \psi R_o^3 - R_i^3}{3\psi R_o^2 - R_i^2} = \frac{2 \times 0.866 \ 631}{\pi \ 29} = 12 \text{ in}$$

where

$R_o = 15.0$  in, outer radius of bearing surface

$R_i = 14.0$  in, inner radius of bearing surface

$\psi = 60^\circ = \pi/3$  radians

61. The load on the traverse bearing between top and bottom carriage is assumed to be distributed triangularly over the whole annulus. According to Equation 19

$$\bar{x}_a = \frac{1}{4} \frac{R_o^2 + R_i^2}{R_o} = \frac{1}{4} \frac{225}{12} = 4.7 \text{ in}$$

where  $R_o = 12.0$  in, outer radius of race

$R_i = 9.0$  in, inner radius of race

Taking moments about the intersection of the pintle center line and  $R_H$ , we have

$$\begin{aligned}\bar{x}_a R_a + \bar{x}_b R_b &= x_t V_T - x_e V_E \\ &+ x W_{TC} + x_g V_g + y_t H_T - y_e H_E - y_g H_g\end{aligned}$$

but

$$\begin{aligned}\bar{x}_b R_b &= 12.0 (R_a + V_E + V_g - V_T - W_{TC}) \\ (4.7 + 12.0) R_a &= 5,540,000 - 911,000 + \\ 88,000 - 19,000 + 4,300,000 - 1,618,000 \\ &- 82,000\end{aligned}$$

$$16.7 R_a = 7,298,000 \text{ lb-in}$$

$$R_a = 437,000 \text{ lb, traverse bearing load}$$

$$R_b = 297,000 \text{ lb}$$

$$R_H = H_T - H_E - H_g = 68,600 \text{ lb}$$

## B. TRAVERSE BEARING

62. The equivalent traverse bearing load is found from Equation 17

$$p = \frac{2}{\pi} \frac{R_a}{R_o^2 - R_i^2} = 4,420 \text{ psi, max. bearing pressure}$$

$$R_e = \pi (R_o^2 - R_i^2) p = 874,000 \text{ lb, equivalent bearing load}$$

Paragraph 10 states that a bearing having a static load capacity of only half the applied load is adequate for this type installation. Such a bearing would be, for example, SKF Thrust Bearing No. 29338 with a static load rating of 475,000 lb. However, this bearing has a nominal outside diameter of 12.6 inches, whereas the bearing in this problem has the much larger diameter of 24 in, proving that the latter would be more than satisfactory. The pressure on the outer bearing surface depends on the value of  $R_b$  shown in Figure 13. The bearing surface extends through an arc of 120 degrees. (See Paragraph 60.)

$$A = \frac{120}{360} (15^2 - 14^2) \pi = 30.4 \text{ in}^2$$

$$\sigma_{br} = \frac{R_b}{A} = \frac{297,000}{30.4} = 9,800 \text{ lb/in}^2$$

This stress, with the bearing motionless, is far less than the bearing strength of steel and therefore is not considered critical (refer to Paragraph 11).

## C. TRUNNION BEARING

63. The maximum trunnion bearing load is 100,000 lb (Paragraph 90, Reference 5). Referring to Paragraph 10, a suitable bearing should be, for example, SKF Bearing No. 23024 which has a basic load rating of 57,000 lb, slightly more than the required half load.

## D. STRESSES OF STRUCTURE

64. Bending stresses are maximum at Section A-A, Figure 14, and occur in two direc-

tions, about the  $x$ - $x$  axis and the  $y$ - $y$  axis. Torsional stresses at this section are zero. The combined bending stresses are maximum at the open end of leg  $b_2$ . To be conservative, assume that the reactions  $R_a$  and  $R_b$  are concentrated at Section A-A.

$$t_1 = 1.0 \text{ in}; \quad t_2 = t_3 = 0.5 \text{ in}$$

$$b_1 = 27 \text{ in}; \quad b_2 = 18 \text{ in}; \quad b_3 = 12 \text{ in}$$

Moment of inertia using  $BL_x$  as the base line is computed as follows:

Dimen- sions	A	d	Ad	Ad <sup>2</sup>	I <sub>o</sub>	I <sub>BL</sub>
0.5×12	6.0	6.0	36.0	216	72	288
0.5×18	9.0	9.0	81.0	729	243	972
27×1.0	27.0	0.5	13.5	7	—	7
Σ	42.0		130.5	952	315	1267

$$\bar{d} = \frac{\Sigma Ad}{\Sigma A} = 3.1 \text{ in}; \quad c_x = 18.0 - 3.1 = 14.9 \text{ in}$$

$$I_x = I_{BL} - \Sigma A\bar{d}^2 = 1267 - 404 = 863 \text{ in}^4$$

$$M_x = \frac{e(V_T + W_{TC} - V_E - V_o)}{2}$$

$$= 14 \times \frac{140,000}{2} = 980,000 \text{ lb-in}$$

$$\sigma_x = \frac{M_x c_x}{I_x} = 16,900 \text{ lb/in}^2$$

Moment of inertia using  $BL_y$  as the base line is:

Dimen- sions	A	d	Ad	Ad <sup>2</sup>	I <sub>o</sub>	I <sub>BL</sub>
17×0.5	8.5	0.25	2	1	—	1
1.0×28	28.0	14.0	392	5488	1828	7316
11×0.5	5.5	27.75	152	4204	—	4204
Σ	42.0		546	9693	1828	11,521

$$\bar{d} = \frac{\Sigma Ad}{\Sigma A} = 13.0 \text{ in}; \quad c_y = \bar{d} = 13.0 \text{ in}$$

$$I_y = I_{BL} - \Sigma A\bar{d}^2 = 11,521 - 7,110 = 4411 \text{ in}^4$$

$$M_y = \frac{e(H_T - H_E - H_o)}{2} = 14 \times \frac{68,600}{2}$$

$$= 480,000 \text{ lb-in}$$

$$\sigma_y = \frac{M_y c_y}{I_y} = 1400 \text{ lb/in}^2$$

$$\sigma = \sigma_x + \sigma_y = 18,300 \text{ lb/in}^2$$

This bending stress is low but the 1-inch thick base plate ( $t_1$  in Figure 14) is needed to support the bearing load (see Paragraph 67). According to this analysis, a thinner plate would be more efficient from the strength

viewpoint but it is better to maintain this size for rigidity. Rigidity is of primary importance in the top carriage structure where excessive deflections may affect accuracy.

65. Torsional stresses in the base are maximum at Section B-B and because of the reactions, gradually reduce to zero at Section A-A (see Paragraph 44). The torsional stress is based on an equivalent system which yields a uniform shear stress over the entire section. From Figure 14 and the following dimensions

$$t_1 = 1.0 \text{ in}; \quad t_2 = t_3 = 0.5 \text{ in}$$

$$b_1 = 16 \text{ in}; \quad b_2 = 18 \text{ in}; \quad b_3 = 12 \text{ in}$$

$$x_o = 3.5 \text{ in}; \quad y_o = 1.5 \text{ in.}$$

Part	A	d <sub>x</sub>	d <sub>y</sub>	Ad <sub>x</sub>	Ad <sub>y</sub>
1	16	8.5	0.5	136.0	8
2	9	0.25	9.0	2.25	81
3	6	16.75	6.0	100.5	36
Σ	31			238.75	125

$$\bar{d}_x = \frac{\Sigma Ad_x}{\Sigma A} = 7.71 \text{ in}; \quad \bar{d}_y = \frac{\Sigma Ad_y}{\Sigma A} = 4.03 \text{ in}$$

$$\bar{x} = x_o - \bar{d}_x = 0.79 \text{ in}; \quad \bar{y} = \bar{d}_y - y_o = 2.53 \text{ in}$$

$$T = \frac{1}{2} [(x_l + \bar{x}) V_T - (x_e + \bar{x}) V_E + (x + \bar{x}) W_{TC} + (x_o - \bar{x}) V_o - (y_e - \bar{y}) H_E + (y_l - \bar{y}) H_T - (y_o - \bar{y}) H_o]$$

$$= \frac{1}{2} [22.29(V_T - V_E) + 10.79W_{TC} + 1.57V_o - 56.97H_E + 39.97H_T - 12.37H_o]$$

$$= \frac{1}{2} (3,080,000 + 43,000 + 3000 - 1,550,000 + 4,050,000 - 68,000)$$

$$T = 2,779,000 \text{ lb-in}$$

The area moment of the section is taken about the same center as the torsional moment

$$M_A = b_1 t_1 (\bar{d}_y - 0.5) + b_2 t_2 (\bar{d}_x - 0.25) + b_3 t_3 (16.75 - \bar{d}_x)$$

$$= 16 \times 3.53 + 9 \times 7.46 + 6 \times 9.04 = 178.8 \text{ in}^3$$

$$\tau = \frac{T}{M_A} = \frac{2,779,000}{178.8} = 15,500 \text{ lb/in}^2$$

torsional stress

66. Section C-C (not detailed) bears investigation as it represents a typical section of the side frames. It is equivalent to a 27 × 3 × ½ in. I-beam. Its neutral axis lies 39.5 inches below and 24.2 in. to the right of the trunnions.

To maintain a factor of safety of 1.5, material having a yield strength of 51,000 lb/in<sup>2</sup> will be used.

$$\begin{aligned}
M &= \frac{1}{2} (24.2V_T + 39.5H_T + 12.7W_{TC} - 24.2V_E - 56.5H_E) \\
&= \frac{1}{2} (3,998,000 + 4,001,000 + 51,000 - 658,000 - 1,537,000) \\
&= 2,928,000 \text{ lb-in, bending moment} \\
F_c &= \frac{1}{2} [(V_T - V_E + W_{TC}) \cos 30^\circ - (H_T - H_E) \sin 30^\circ] \\
&= \frac{1}{2} (142,000 \times 0.866 - 74,100 \times 0.50) = 43,000 \text{ lb, compressive force} \\
A &= 2 \times \frac{1}{2} \times 3 + \frac{1}{2} \times 26 = 16 \text{ in}^2 \\
I &= \frac{1}{12} \times \frac{1}{2} \times 26^3 + 2 \times \frac{1}{2} \times 3 \times 13.25^2 = 732 + 527 = 1,259 \text{ in}^4 \\
\sigma_b &= \frac{Mc}{I} = \frac{2,928,000 \times 13.5}{1,259} = 31,400 \text{ lb/in}^2 \text{ (bending)} \\
\sigma_c &= \frac{F_c}{A} = \frac{43,000}{16} = 2,700 \text{ lb/in}^2 \text{ (compression)} \\
\sigma &= \sigma_b + \sigma_c = 34,100 \text{ lb/in}^2 \text{ total stress}
\end{aligned}$$

#### E. BASE PLATE

67. The base plate is assumed to be a flat circular plate with outer edge fixed and supported and the inner edge stiffened to prevent it from rotating. Local reinforcements strengthen the plate by converting its effective radii to those of the traverse bearing race (see Paragraph 61). It is further assumed that the maximum bearing pressure is distributed uniformly over the entire surface (see Paragraphs 18 and 62). Because of the actual triangular load distribution and because of the local reinforcements, the analysis is conservative, hence the apparent stress, although only slightly less than the yield strength of 51,000 lb/in<sup>2</sup>, indicates adequate strength to render the structure acceptable.

$$\begin{aligned}
\sigma &= \frac{3w}{4t^3} \left[ (a^2 + b^2) \frac{4a^2b^2}{a^2 - b^2} \left( \ln \frac{a}{b} \right) \right] \\
&= 46,200 \text{ lb/in}^2*
\end{aligned}$$

where  $t = 1.0$  in, plate thickness  
 $w = p = 4420$  lb/in<sup>2</sup> pressure on plate  
 (see Paragraph 62)  
 $a = 12$  in, outer radius  
 $b = 9$  in, inner radius  
 $\ln \frac{a}{b} = 0.285$

\* Reference 11, Page 200, Table X, Case 19. Reprinted by permission from *Formulas for Stress and Strain*, 3rd Ed., by R. J. Roark, Copyright 1954, McGraw-Hill Book Co., Inc.

#### F. TRUNNION CAP BOLTS

68. The trunnion cap bolts have loads from two sources acting on them; one from the equilibrator, the other from the bending moment in the bearing housing. As two caps are involved, all loads are distributed evenly between them. Referring to Figure 19a, the load at 1 produced by the equilibrator is found by taking moments about 2.

$$R'_1 = \frac{1}{2} \frac{yH_E - xV_E}{21} = 19,700 \text{ lb}$$

where  $H_E = V_E = 27,200$  lb (see Paragraph 60)  
 $x = 9.85$  in  
 $y = 20.58$  in

The second component of the bolt load is a force of the couple resisting the bending moment at the joint. If the bearing housing, both cap and base, is considered a ring with an internal load uniformly distributed on the diameter of its centroidal axis (Figure 19b), a variable bending moment results at the periphery to put the bolt in tension and the inner rim in compression (Figure 19c). The moment is calculated by the method derived from the material of Article 57, Reference 12 and is based on the assumption that the minimum cross section of the base extends over the total periphery. This assumption is conservative because any increase in cross section will make the ring stiffer. The maximum moment occurs when the horizontal trunnion

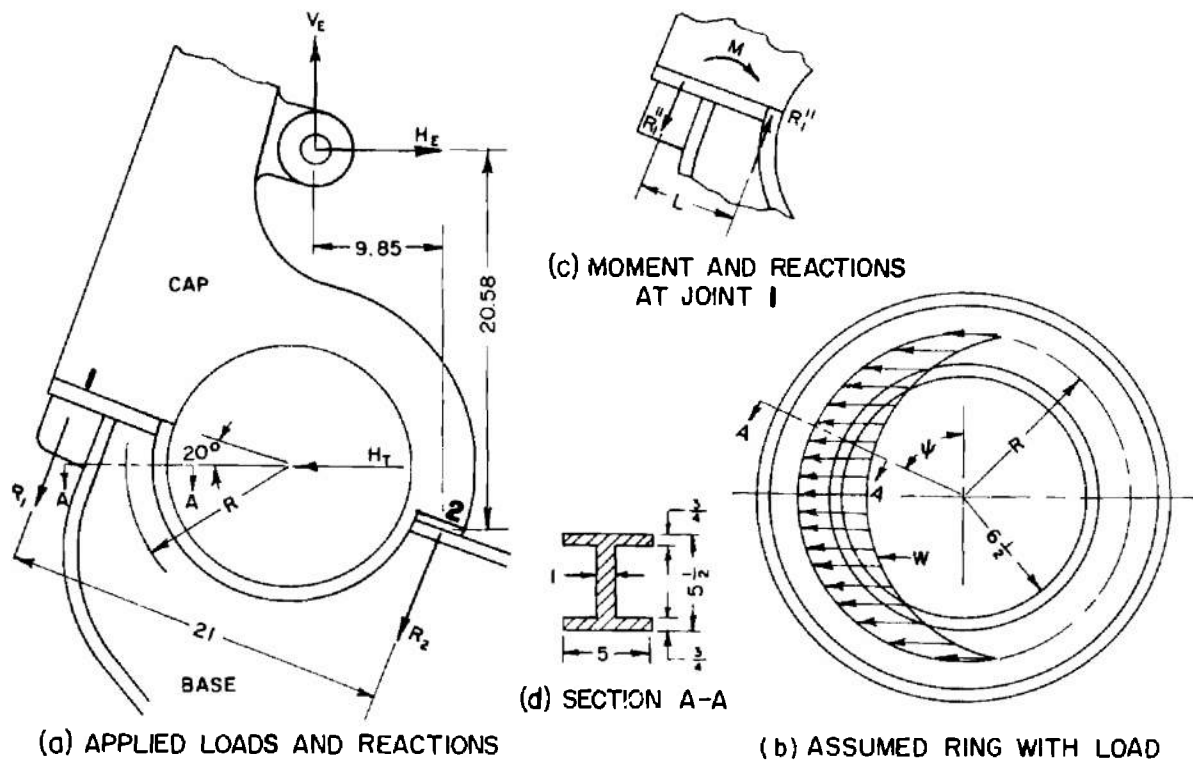

Figure 19. Trunnion Cap Loading Diagram

load,  $H_T$ , is maximum. Referring to Figure 19, the bending moment at I is

$$M = -\frac{1}{8} WR [1 - 4(1 - \cos \psi) + 2(1 - \cos \psi)^2] = 0.0958WR = 86,000 \text{ lb-in}$$

where  $W = \frac{1}{2} H_T = 97,000 \text{ lb}$ , maximum load (assumed)

$R = 6.5 + 2.75 = 9.25 \text{ in}$ , radius to centroidal axis

$\psi = 70^\circ$   
 $H_T = (F_A^2 + F_N^2)^{1/2} = 194,000 \text{ lb}$ , the resultant trunnion load, assumed to be horizontal

The bolt load due to the moment is

$$R_1' = \frac{M}{L} = 12,500 \text{ lb}$$

where  $L = 6.875 \text{ in}$ , the distance between the bolt and the center of the inner rim.

The total bolt load becomes

$$R_1 = R_1' + R_1'' = 32,200 \text{ lb}$$

If a  $1\frac{1}{4}$ -7NC bolt having a root area of  $0.89 \text{ in}^2$  is selected, its tensile stress will be

$$\sigma = \frac{32,200}{0.89} = 36,200 \text{ lb/in}^2$$

which will require a yield strength of  $55,000 \text{ lb/in}^2$  to insure a factor of safety of 1.5.

## X. SAMPLE PROBLEM II, DOUBLE RECOIL TYPE

### A. LOAD ANALYSIS

69. This problem concerns a top carriage for a double recoil type weapon similar to Figure 15. The applied loads and secondary acceleration are obtained from the Sample Problem, O-Type Cradle, Reference 5.

- $F_B = 35,300 \text{ lb}$ , equilibrator force
- $R_g = 36,100 \text{ lb}$ , elevating gear load
- $F_A = 111,800 \text{ lb}$ , trunnion load parallel to bore
- $F_N = 43,800 \text{ lb}$ , trunnion load normal to bore
- $W_c = 4,000 \text{ lb}$ , weight of cradle
- $W_1 = 10,000 \text{ lb}$ , weight of primary recoiling parts

$W_2 = 14,000$  lb, weight of secondary recoiling parts including weight of top carriage

From the same reference

$$\begin{aligned}\lambda &= 20^\circ \\ \rho &= 90 + \beta - \gamma = 85^\circ \\ \theta &= 60^\circ\end{aligned}$$

The vertical and horizontal components of the applied loads are determined from expressions similar to those of Equations 21a through 21f.

$$H_T = F_A \cos \theta - F_N \sin \theta = 55,900 - 37,900 = 18,000 \text{ lb}$$

$$V_T = F_A \sin \theta + F_N \cos \theta = 96,800 + 21,900 = 118,700 \text{ lb}$$

$$H_E = F_E \cos \lambda = 33,200 \text{ lb}$$

$$V_E = F_E \sin \lambda = 12,100 \text{ lb}$$

$$H_o = R_o \cos \rho = 3,150 \text{ lb}$$

$$V_o = R_o \sin \rho = 36,000 \text{ lb}$$

$$W'_2 = 4,000 \text{ lb, top carriage weight, front of trunnions}$$

$$W''_2 = 3,500 \text{ lb, top carriage weight, rear of trunnions}$$

$$W_B = 2,500 \text{ lb, weight of bogie}$$

In Figure 15 assign the following lengths (inches)

$$\begin{aligned}x_B &= 116.0 & y_B &= 15.0 \\ x_E &= 48.0 & y_E &= 30.9 \\ x_o &= 32.6 & y_o &= 15.2 \\ x' &= 36.0 & y' &= 29.0\end{aligned}$$

$$\begin{aligned}x'_R V_T &= 100 \times 118,700 = 11,870,000 \\ -y_R H_T &= -44 \times 18,000 = -792,000 \\ (x'_R - x'') W''_2 &= 30 \times 3,500 = 105,000 \\ (y_R - y'') H'_2 &= 15 \times 5,000 = 75,000 \\ (x'_R + x_o) V_o &= 132.6 \times 36,000 = 4,770,000 \\ -(y_R - y_o) H_o &= -28.8 \times 3,150 = -91,000 \\ -(x'_R + x_E) V_E &= -148 \times 12,100 = -1,791,000 \\ -(y_R - y_E) H_E &= -13.1 \times 33,200 = -435,000 \\ (x'_R + x') W'_2 &= 136 \times 4,000 = 544,000 \\ (y_R - y') H'_2 &= 15 \times 5,700 = 86,000 \\ (x'_R + x_B) W_B &= 216 \times 2,500 = 540,000 \\ (y_R - y_B) H_B &= 29 \times 3,600 = 104,000 \\ \hline 140 R'_F &= 14,985,000 \text{ lb-in}\end{aligned}$$

$$R'_F = 107,000 \text{ lb}$$

$$R'_R = 152,600 - R'_F = 45,600 \text{ lb}$$

$$\mu R'_F = 0.15 R'_F = 16,100 \text{ lb}$$

$$\mu R'_R = 0.15 R'_R = 6,800 \text{ lb}$$

$$x'' = 70.0 \quad y'' = 29.0$$

$$x_R = 40.0 \quad y_R = 44.0$$

$$x = 140.0 \quad y_r = 0$$

$$x'_R = 100.0$$

In Reference 5, Paragraph 62, the acceleration of the secondary recoiling mass is

$$a_2 = 1.43g$$

$$H_B = W_B a_2 = 3600 \text{ lb}$$

$$H'_2 = W'_2 a_2 = 5700 \text{ lb}$$

$$H''_2 = W''_2 a_2 = 5000 \text{ lb}$$

From Equation 29

$$R'_F + R'_R = V_T + V_o - V_E + W'_2 + W''_2 + W_B = 152,600 \text{ lb}$$

The coefficient of friction on the basis of past experience is  $\mu = 0.15$ ,\* thus from Equation 29a

$$\mu(R'_F + R'_R) = 22,900 \text{ lb, frictional resistance on the slides}$$

Equation 30a states that the secondary recoil rod pull is

$$R_r = H_T + H_o + H_E - F_2 - H_B - \mu(R'_F + R'_R) = 17,150 \text{ lb}$$

where  $F_2 = H'_2 + H''_2$ . In Figure 15, take moments about the intersection of  $R'_R$  and  $\mu R'_R$  and equate to  $xR'_F$ .

$$\begin{aligned}xR'_F &= x'_R V_T - y_R H_T + (x'_R - x'') W''_2 \\ &+ (y_R - y'') H'_2 + (x'_R + x_o) V_o - (y_R - y_o) H_o \\ &- (x'_R + x_E) V_E - (y_R - y_E) H_E + (x'_R + x') W'_2 \\ &+ (y_R - y') H'_2 + (x'_R + x_B) W_B + (y_R - y_B) H_B\end{aligned}$$

\* Reference 13.

70. The loads and reactions are now determined for the transport condition. Figure 11 shows the forces and dimensions involved in this analysis. In Figure 11 assign the following lengths (inches)

$$\begin{array}{ll} x = 216 & x_F = 60 \\ x_B = 100 & x_T = 40 \\ x_L = 116 & x_V = 90 \\ x' = 36 & x_E = 48 \\ x'' = 70 & y_E = 30.9 \end{array}$$

71. All the applied loads are derived from the weight of the various components except for the equilibrator load which is the load necessary for balancing the tipping parts at zero elevation. Following the same procedure as for the firing condition at 60° elevation, the weight moment is

$$M_w = 75W_1 + 25W_c = 850,000 \text{ lb-in}^*$$

$$F_E = \frac{M_w}{r} = 46,400 \text{ lb, equilibrator force}$$

where  $r = 18.3$ , the equilibrator moment arm.

\* Reference 5, Paragraph 63.

For  $\lambda = 14^\circ$  (see Figure 11)

$$\begin{aligned} H_E &= F_E \cos \lambda = 45,000 \text{ lb} \\ V_E &= F_E \sin \lambda = 11,200 \text{ lb} \end{aligned}$$

This equilibrator force exists during transport but the recoiling parts are retracted to a more favorable position so that their center of gravity shifts to a new location; in this case to 10 inches in front of the trunnions. Now, taking moments about the trunnions,

$$\begin{aligned} x_V V_H &= M_w - (10W_1 + 25W_c) \\ 90V_H &= 650,000 \\ V_H &= 7,200 \text{ lb} \end{aligned}$$

where  $V_H$  is the load at the hold-down fitting.

$$\begin{aligned} V_T &= W_1 + W_c + V_E - V_H = 18,000 \text{ lb} \\ H_T &= H_E = 45,000 \text{ lb} \\ W_T &= 1,400 \text{ lb, weight of turntable assembly} \\ W_F &= 600 \text{ lb, weight of float assembly} \\ W_{BC} &= W_T + W_F, \text{ weight of bottom carriage} \\ W'_2 &= 4,000 \text{ lb, top carriage weight (front)} \\ W''_2 &= 3,500 \text{ lb, top carriage weight (rear)} \end{aligned}$$

72. The loads on the wheel axles are found by taking moments about the limber axle.

$$\begin{aligned} xR_B &= (x_L + x')W'_2 + (x_L - x'')W''_2 + x_L V_T + (x_L + x_T)W_T \\ &+ (x_L - x_F)W_F - (x_L + x_E)V_E + y_E H_E + (x_L - x_V)V_H \\ (x_L + x')W'_2 &= 152 \times 4,000 = 608,000 \\ (x_L - x'')W''_2 &= 46 \times 3,500 = 161,000 \\ x_L V_T &= 116 \times 18,000 = 2,088,000 \\ (x_L + x_T)W_T &= 156 \times 1,400 = 218,000 \\ (x_L - x_F)W_F &= 56 \times 600 = 34,000 \\ -(x_L + x_E)V_E &= -164 \times 11,200 = -1,838,000 \\ (x_L - x_V)V_H &= 26 \times 7,200 = 187,000 \\ y_E H_E &= 30.9 \times 45,000 = 1,390,000 \\ 216 R_B &= 2,848,000 \end{aligned}$$

$$R_B = 13,200 \text{ lb}$$

$$R_L = W'_2 + W''_2 + V_T + W_T + W_F - V_E + V_H - R_B = 10,300 \text{ lb}$$

#### Firing Conditions Based on a 1.5 Load Factor

Station	$\Delta x$	$V$	$\Sigma V$	$H$	$\Delta y$	$M_x$	$M_y$	$M$
116	0	-38	-38	-54	14	0	-76	-76
90	26	0	-38	0	0	-99	0	-175
48	42	182	144	498	-1.9	-160	-95	-430
40	8	1605	1749	-499	-15	115	749	434
36	4	-60	1689	-85	0	700	0	1134
32.6	3.4	-540	1149	47	13.8	574	65	1773
0	32.6	-1781	-632	270	29	3746	783	6302
-70	70	-52	-684	-75	0	-4417	0	1885
-100	30	684	0	-102	-15	-2052	153	-14

Units of  $\Delta x$  and  $\Delta y$  are given in inches;  $V$ ,  $\Sigma V$ , and  $H$  in 100 lb;  $M_x$ ,  $M_y$ , and  $M$  in 1000 lb-in.



*Transport Conditions Based on a 3.0 Load Factor*

station	$\Delta x$	$V$	$\Sigma V$	$H$	$\Delta y$	$M_x$	$M_y$	$M$
100	0	396	396	0	0	0	0	0
90	10	0	396	0	0	396	0	396
48	42	336	732	1350	-1.9	1662	-258	1800
40	8	-42	690	0	0	585	0	2385
36	4	-120	570	0	0	276	0	2661
0	36	-540	30	-1350	29	2052	-3915	798
-60	60	-18	12	0	0	180	0	978
-70	10	-105	-93	0	0	12	0	990
-90	20	-216	-309	0	0	-186	0	804
-116	26	309	0	0	0	-804	0	0

Units of  $\Delta x$  and  $\Delta y$  are given in inches;  $V$ ,  $\Sigma V$ , and  $H$  in 100 lb;  $M_x$ ,  $M_y$ , and  $M$  in 1000 lb-in.

73. With the loads and reactions determined for both firing and transport conditions, the design bending moment diagrams are constructed to learn which condition is critical at various stations along the side frames. Referring to Paragraph 32, the firing loads are multiplied by a factor of 1.5 and the transport loads by 3.0. The stations are located with respect to the trunnions, positive to the left. For the initial survey, assume that the neutral axis of the side frame lies 15 inches above the slides. Clockwise moments, loads upward, and loads to the right are positive.

#### B. SIDE FRAME ANALYSIS

74. We now have the information necessary to determine the size of the side frames. The moment diagrams in Figure 20 show that the maximum moment occurs at Station 0 and that the firing condition is critical. The largest section will be at Station 0. The design bending moment is 6,302,000 lb-in but this is for both side frames and it also includes a load factor of 1.5. The true moment is

$$M = \frac{1}{2} \times \frac{6,302,000}{1.5} = 2,101,000 \text{ lb-in}$$

With the desired factor of safety of 1.5 and a yield strength of 60,000 lb/in<sup>2</sup>, the allowable bending stress is

$$\sigma_a = \frac{60,000}{1.5} = 40,000 \text{ lb/in}^2$$

and the required section modulus is

$$\frac{I}{c} = \frac{M}{\sigma_a} = 52.5 \text{ in}^3$$

A cross section at Station 0 is selected on the basis of the above requirement. Assume an

I-beam section similar to the one in Figure 16.

$$\begin{aligned} \text{If} \quad w &= 3.0 \text{ in} \\ e &= 1/2 \text{ in} \\ t &= 3/16 \text{ in} \end{aligned}$$

then  $2A_f = 2ew = 3.0 \text{ in}^2$ , total flange area

The expression for the approximate section modulus is

$$\frac{I}{c} \approx \frac{\left[ 2A_f \left( \frac{h_w}{2} \right)^2 + \frac{1}{12} th_w^3 \right]}{\frac{1}{2} h_w} = 52.5 \text{ in}^3$$

$$h_w^2 + 48h_w - 1680 = 0$$

$$h_w = 23.5 \text{ in}$$

Further investigation shows that a web depth,  $h_w$ , of 24 inches yields the required moment of inertia

$$I = 2A_f \left( \frac{h_w}{2} + e \right)^2 + \frac{1}{12} th_w^3 = 450 + 216 = 666 \text{ in}^4$$

$$c = \frac{h_w}{2} + e = 12.5 \text{ in}$$

$$\sigma = \frac{Mc}{I} = \frac{2,101,000 \times 12.5}{666} = 39,500 \text{ lb/in}^2$$

$$S_f = \frac{60,000}{39,500} = 1.52$$

75. Because the bending moment is not constant throughout its span, the side frame may taper to shallower depths provided the reduced section has adequate shear strength. From the table in Paragraph 73, the maximum shear of 174,900 lb is observed at Station 40. The actual shear on one side frame is

$$V = \frac{1}{2} \frac{174,900}{1.5} = 58,300 \text{ lb}$$

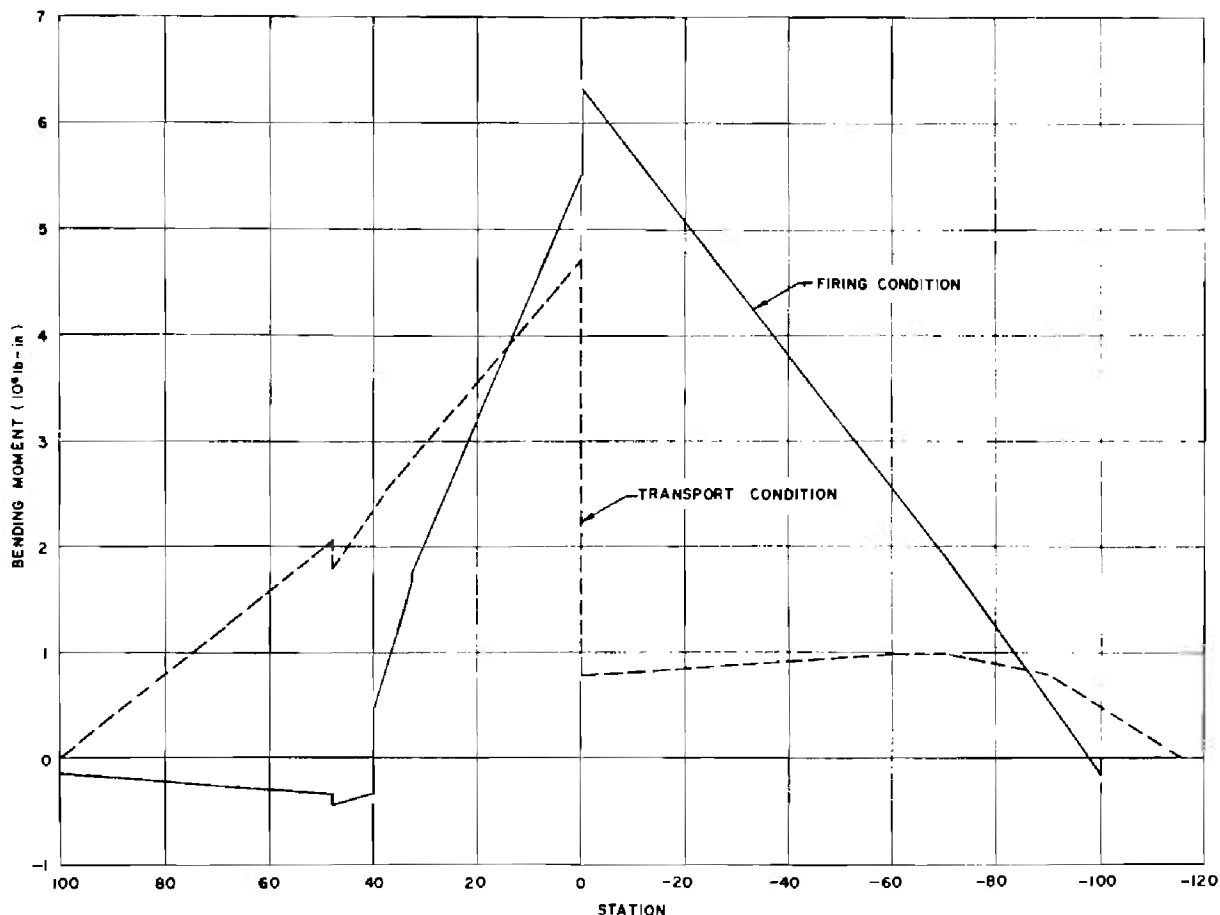

Figure 20. Design Bending Moment of Side Frame

The beam is too deep for the direct shear stress to have any significance; the shear stress along the neutral axis being critical. After investigating sectional properties, we learn that the beam at Station 40 must be the same size as that at Station 0.

$$\bar{y} = \frac{\sum A y}{\sum A_a} = \frac{1.5 \times 12.25 + 0.1875 \times 12 \times 6.0}{1.5 + 2.25} = 8.5 \text{ in}$$

From Equation 37

$$\tau_a = \frac{V A a \bar{y}}{I t} = 14,900 \text{ lb/in}^2$$

If it includes the 1.5 factor of safety, the shear stress becomes

$$\tau_m = 22,400 \text{ lb/in}^2$$

Entering this value into Equation 41, the approximate solution for the stiffener spacing is

$$d^2 = 6.58 \frac{E t^2}{\tau_m} = 296 \text{ in}^2$$

$$d = 17.2 \text{ in}$$

76. The above result can be checked by Equation 42. This more rigorous analysis increases the stiffener spacing to 21 inches. Thus

$$\frac{a}{b} = \frac{24}{21} = 1.14 \text{ and } K = \frac{1}{2} (8.0 + 13.6) = 10.8$$

The crippling stress

$$\sigma_{cr} = K \frac{\pi^2 E}{12(1 - \nu^2)} \left( \frac{t}{b} \right)^2 = 22,600 \text{ lb/in}^2$$

where  $b = 21 \text{ in}$

$$E = 29 \times 10^6 \text{ lb/in}^2$$

$$t = 3/16 \text{ in}$$

$$\nu = 0.3$$

$$S_f = \frac{\sigma_{cr}}{\tau} = \frac{22,600}{14,900} = 1.51$$

77. Now that the spacing is known, calculate the required moment of inertia of the stiffeners. First increase the vertical shear by the load factor of 1.5, otherwise more than one operation becomes necessary. From Equation 43

$$I_s = \frac{d}{t} \left( \frac{V_m h_w}{17.7E} \right)^{4/3} = 0.073 \text{ in}^4$$

where  $d = 21 \text{ in}$   
 $h = 24 \text{ in}$   
 $t = 3/16 \text{ in}$   
 $V_m = 1.5V = 1.5 \times 58,300 = 87,500 \text{ lb}$   
 $E = 29 \times 10^6 \text{ lb/in}^2$

The above value suggests a square tube with cross section of  $1.1 \times 1.1$  inch having a 0.12 inch wall. It is formed by welding the open ends of a channel to each side of the web. Its moment of inertia is

$$I_s = \frac{1}{12} (1.10^4 - 0.86^4) = 0.0764 \text{ in}^4$$

Insert this value in Equation 43 and solve for  $V_m$ , the allowable load.

$$V_m = 90,500 \text{ lb}$$

$$S_f = \frac{V_m}{V} = \frac{90,500}{58,300} = 1.55$$

## GLOSSARY

- angle of elevation.** The angle between the center line of the bore and the horizontal.
- base plate.** The bottom structure of a top carriage, integral with or rigidly attached to the side frames.
- bearing, traverse.** The combined radial and thrust bearing on which the top carriage traverses.
- bearing, trunnion.** The bearing that holds the trunnion.
- bogie.** The rear transporting unit of a gun carriage.
- buffer.** The shock absorber for the counter-recoiling parts.
- buffing force.** The resistance provided by the buffer to the counterrecoiling parts.
- carriage.** The supporting structure of a weapon.
- carriage, bottom.** The secondary supporting structure of a gun. It supports the top carriage.
- carriage, top.** Primary supporting structure of a weapon. It supports the tipping parts and moves with the cradle in traverse. In double recoil systems it comprises the bulk of the secondary recoiling mass.
- clearance, ground.** The space between the breech and ground at the end of recoil at the highest angle of elevation. The under-carriage clearance during transport.
- clip.** The component of a discontinuous guide used for alignment of recoiling parts.
- cradle.** The nonrecoiling structure of a weapon which houses the recoiling parts and rotates about the trunnions to elevate the gun.
- equilibrator.** The force-producing mechanism whose function is to provide a moment about the cradle trunnions equal and opposite to that caused by the muzzle preponderance of the tipping parts.
- factor, load.** The ratio of design load to actual load.
- factor of safety.** The ratio of material strength to stress.
- firing conditions.** The various loads imposed on the weapon during all phases of firing.
- firing position, horizontal.** The position of a weapon on a horizontal plane at zero angle of elevation.
- frames, side.** The side structure of the top carriage, the immediate supports of the trunnions.
- limber.** The front transporting unit of a weapon.
- loading device.** Equipment used for transferring ammunition into the firing chamber of weapons.
- loading trough.** A structure with side retainers that is used to carry the ammunition as it is rammed into the breech.
- load, running.** The applied loads on bearings while in motion.
- mechanism, elevating.** The mechanism that transmits power to the tipping parts during change in elevation.
- mechanism, traversing.** The mechanism that transmits power to the traversing parts.
- mount.** The supporting structure of a weapon that transmits the firing loads to the ground or to another structure.
- pintle.** The stanchion about which the weapon traverses.
- racer.** The flat circular annulus which forms the contact surface of the rolling elements of a bearing.
- rail.** The sliding member of the supporting structure for the recoiling parts.
- recoil cycle.** The sequence of activity after a gun is fired; recoil, counterrecoil, buff.
- recoil force.** The resistance provided to the recoiling parts by the recoil system.
- recoil mechanism.** The unit that absorbs some of the energy of recoil and stores the rest for returning the recoiling parts to battery.
- recoil system, double.** A system in which the gun recoils on the top carriage and the top carriage recoils on the bottom carriage.

**recoil system, single.** A system that has only the gun tube and its components as recoiling parts.

**recoil stroke.** During recoil, the distance traveled by the recoiling parts.

**stiffener.** A slender structural member attached to the web of beams to prevent the web from buckling.

**tipping parts.** The assembled structure of a weapon that rotates about the trunnions.

**transport conditions.** The various loads imposed on the weapon during all phases of transport; the relative position of parts when

the weapon is prepared for transport.

**traverse, limited.** The training of a weapon in azimuth through an arc limited by the structure.

**traverse, unlimited.** The training of a weapon in azimuth in either direction without limit.

**trunnion cap.** The removable portion of the trunnion bearing housing.

**trunnion height.** The distance measured from the ground to the center of the trunnions when the weapon rests on a horizontal plane.

## REFERENCES

1. ORDP 20-340, Ordnance Engineering Design Handbook, Carriages and Mounts Series, *Carriages and Mounts—General*.
2. *SKF General Catalogue No. 350*, 2nd Edition.
3. ORDP 20-342, Ordnance Engineering Design Handbook, Carriages and Mounts Series, *Recoil Systems*, February 1960.
4. ORDP 20-345, Ordnance Engineering Design Handbook, Carriages and Mounts Series, *Equilibrators*, April 1960.
5. ORDP 20-341, Ordnance Engineering Design Handbook, Carriages and Mounts Series, *Cradles*, September 1960.
6. ORDP 20-134, Ordnance Engineering Design Handbook, *Maintenance Engineering Principles for Design Engineers*.
7. ORDP 20-301, Ordnance Materials Handbook, *Aluminum and Aluminum Alloys*, March 1956.
8. S. Timoshenko, *Theory of Elasticity*, 2d Ed., McGraw-Hill Book Co., Inc., New York, 1951.
9. E. F. Bruhn, *Analysis and Design of Airplane Structures*, John S. Swift, Inc., Cincinnati, 1943.
10. H. Wagner, "Sheet-Metal Airplane Construction," AER-53-18-151, *Trans. ASME*, 1931.
11. R. J. Roark, *Formulas for Stress and Strain*, 3d Ed., McGraw-Hill Book Co., Inc., New York, 1954.
12. F. B. Seely and J. O. Smith, *Advanced Mechanics of Materials*. John Wiley and Sons, Inc., New York, 1952.
13. *A Report on the Analysis of Gun Carriage, 175mm, T76*, The Franklin Institute, Final Report F-2240, Part III.

## INDEX

- Base plate, 21
- Bearings
  - design of, 2, 3
  - traversing mechanism, 3, 19
  - trunnion, 2, 19
- Construction
  - double recoil type, 10
  - general, 9
  - single recoil type, 10
- Design
  - of bearings, 2, 3
  - problems, 18, 22
  - procedures, 8
  - schedule, 8
- Elevating mechanisms, 2
- Equilibrators, 1
- Glossary, 28
- Illustrations, list of, iv
- Inspection, 11
- Load analysis
  - conditions, 12
  - double recoil type, 15, 22
  - side frame panel, 16, 25
  - single recoil type, 12, 18
- Location, 10
- Lubrication, 11
- Maintenance, 11
- Manufacturing procedures, 11
- Materials, 12
- References, 30
- Sample problems, 18, 22
- Side frame analysis, 16, 25
- Stress analysis, *see* Load analysis
- Structure, 9, 16, 19, 25
- Symbols, list of, v
- Top carriage
  - construction, 9
  - double recoil type, 7
    - construction, 10
  - functions of, 1
  - operating units, 10
  - single recoil type, 7
    - construction, 10
- Traverse
  - bearing, 3, 19
  - types of, 6
- Traversing mechanisms, 2
- Trunnion
  - bearing, 2, 19
  - cap bolts, 21