

INCH-POUND

AND10050 REV 21
 30 March 2005
 SUPERSEDING
 AND10050 REV 20
 27 May 2003

DETAIL SPECIFICATION SHEET

BOSSES, STANDARD DIMENSIONS FOR
 GASKET SEAL STRAIGHT THREAD

This specification is approved for use by all Departments
 and Agencies of the Department of Defense.

The requirements for acquiring the product described herein shall consist of this specification sheet.

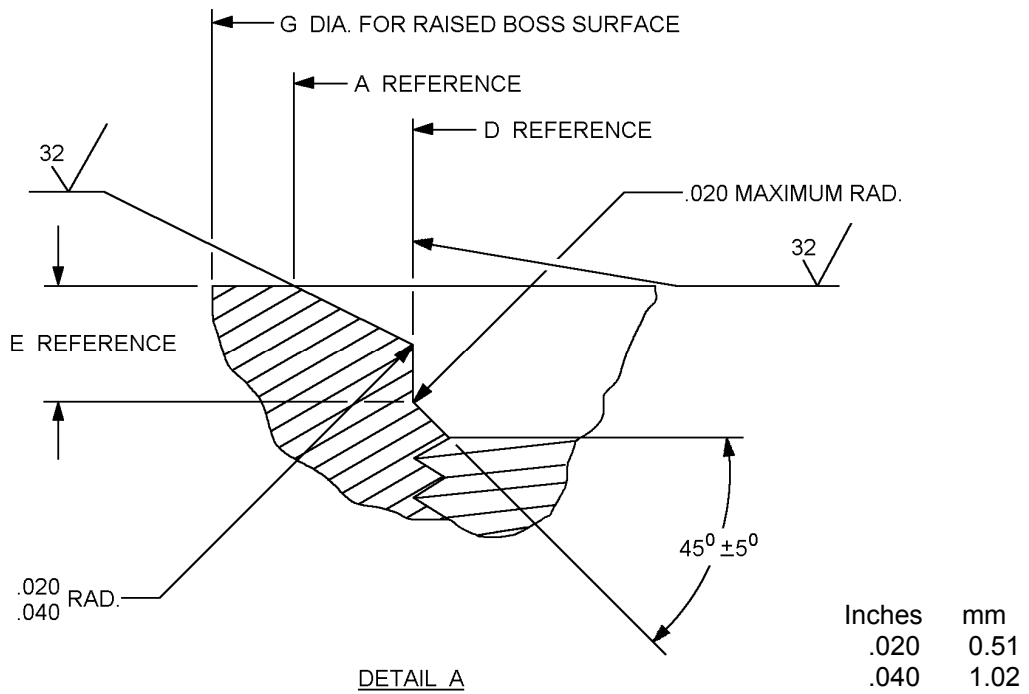
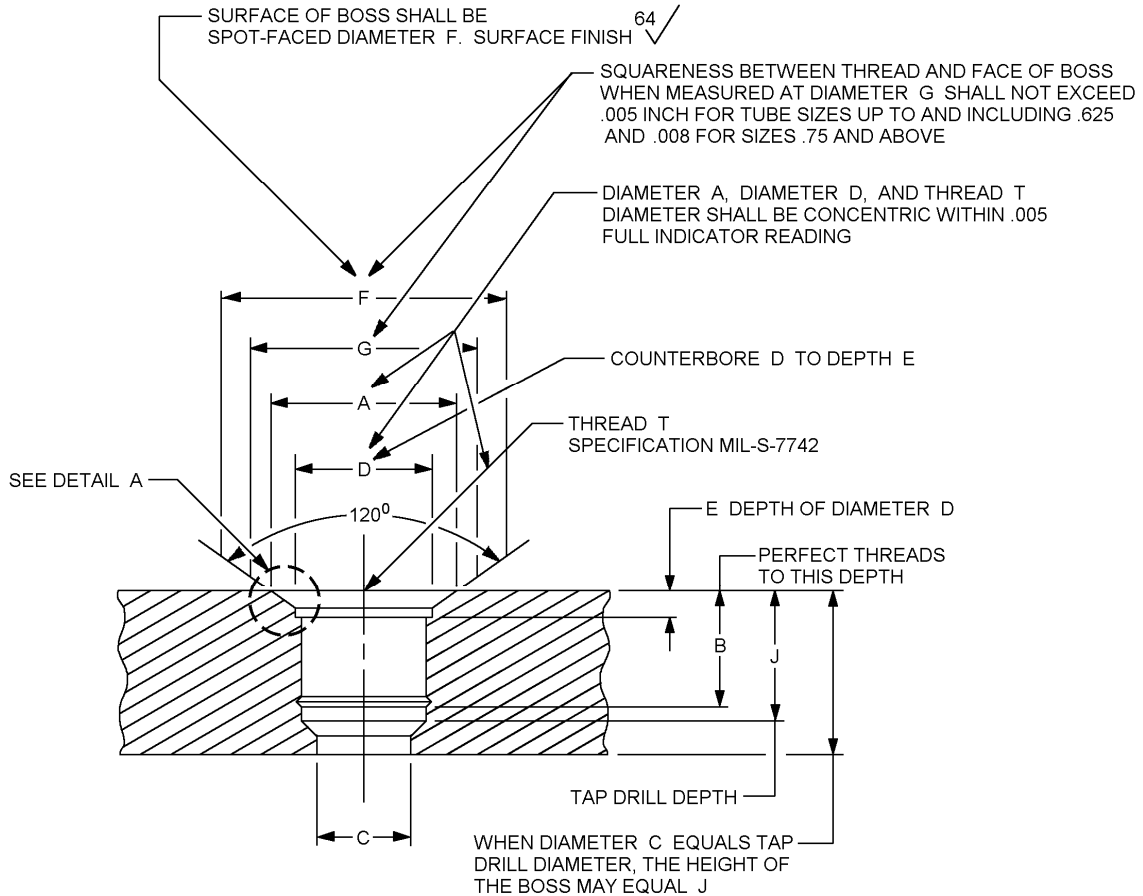

FIGURE 1. Bosses, standard dimensions for gasket seal straight thread.

AND10050 REV 21



NOTE: CLEARANCE SHALL BE PROVIDED FOR USE OF A STANDARD WRENCH

Inches	mm
.005	0.13
.008	0.20
.625	15.88
.75	19.05

FIGURE 1. Bosses, standard dimensions for gasket seal straight thread - Continued.

AND10050 REV 21

Equivalent tube size dash number	Tubing OD	Thread T (Ref)	A +.015 (+0.38) -.000 (mm)	B min (mm)	C dia min (mm)	D dia +.005 (0.13) -.000 (mm)	E +.015 (0.38) -.000 (mm)	F dia min (mm)	G dia min (mm)	J min (mm)	
2	1/8	.3125-24 UNF-3B	.438 (11.13)	.375 (9.53)	.062 (1.57)	.328 (8.33)	.063 (1.60)	.672 (17.07)	.562 (14.27)	.500 (12.70)	
3	3/16	.3750-24 UNF-3B	.500 (12.70)	.406 (10.31)	.125 (3.18)	.390 (9.90)		.750 (19.05)	.625 (15.88)		
4	1/4	.4375-20 UNF-3B	.562 (14.27)	.438 (11.13)	.172 (4.37)	.454 (11.53)	.075 (1.91)	.828 (21.03)	.688 (17.48)	.594 (15.09)	
5	5/16	.500-20 UNF-3B	.625 (15.88)		.234 (5.94)	.517 (13.13)		.906 (23.01)	.750 (19.05)		
6	3/8	.5625-18 UNF-3B	.688 (17.48)	.469 (11.91)	.297 (7.54)	.580 (14.73)	.083 (2.11)	.969 (24.61)	.812 (20.62)		
8	1/2	.750-16 UNF-3B	.875 (22.23)	.562 (14.27)	.391 (9.93)	.769 (19.53)	.094 (2.39)	1.188 (30.18)	1.032 (26.21)		.718 (18.24)
10	5/8	.8750-14 UNF-3B	1.000 (25.40)	.625 (15.88)	.484 (12.29)	.896 (22.76)	.107 (2.72)	1.344 (34.14)	1.157 (29.39)	.781 (19.84)	
12	3/4	1.0625-12 UN-3B	1.234 (31.34)	.688 (17.48)	.609 (15.47)	1.086 (27.58)	.125 (3.18)	1.625 (41.28)	1.406 (35.71)	.906 (23.01)	
16	1	1.3125-12 UN-3B	1.487 (37.77)		.844 (21.44)	1.336 (33.93)		1.910 (48.51)	1.656 (42.06)	.938 (23.83)	
20	1-1/4	1.6250-12 UN-3B	1.800 (45.72)		1.078 (27.38)	1.648 (41.86)		2.270 (57.66)	1.969 (50.01)	.984 (24.99)	
24	1-1/2	1.8750-12 UN-3B	2.050 (52.07)		.750 (19.05)	1.312 (33.32)		1.898 (48.21)	2.560 (65.02)	2.219 (56.36)	1.125 (28.58)
28	1-3/4	2.250-12 UN-3B	2.425 (61.60)		.812 (20.62)	1.547 (39.29)		2.273 (57.73)	3.010 (76.45)	2.594 (65.89)	1.250 (31.75)
32	2	2.500-12 UN-3B	2.675 (67.95)	.938 (23.83)	1.781 (45.24)	2.524 (64.11)		3.480 (88.39)	2.844 (72.24)	1.375 (34.93)	

NOTES:

1. Dimensions are in inches.
2. Metric equivalents are given for information only.
3. Unless otherwise specified angular tolerances + .500°.
4. Finish: Surface texture symbols are defined in ASME Y14.36.
5. Measurements for surface finish: Roughness average is defined in ASME B46.1.

FIGURE 1. Bosses, standard dimensions for gasket seal straight thread - Continued.

AND10050 REV 21

REQUIREMENTS:

Dimensions and configurations: See figure 1.

The countersink to diameter A and counterbore to diameter D shall be free from longitudinal and spiral tool marks.

Break all sharp edges, remove all hanging burrs and slivers, which might become dislodged under usage.

Certain provisions of this standard are subject of international standardization agreement STANAG 3323. ED.5(1) When revision or cancellation of this standard is proposed, the departmental custodians will inform their respective departmental standardization offices so that appropriate action may be taken respecting the international agreement concerned.

Changes from previous issue. The margins of this specification are marked with vertical lines to indicate where changes from the previous issue were made. This was done as a convenience only and the Government assumes no liability whatsoever for any inaccuracies in these notations. Bidders and contractors are cautioned to evaluate the requirements of this document based on the entire content irrespective of the marginal notations and relationship to the last previous issue."

This document references the following:

MIL-S-7742
ASME Y14.36
ASME B46.1
STANAG 3323 ED.5(1)

CONCLUDING MATERIAL

Custodians:
Air Force - 99
DLA - CC

Preparing activity:
DLA - CC

(Project 4730-2646-000)

Review activity:
Air Force - 06, 71

NOTE: The activities listed above were interested in this document as of the date of this document. Since organizations and responsibilities can change, you should verify the currency of the information above using the ASSIST Online database at <http://assist.daps.dla.mil>.