

FSC 2935

This drawing was approved by joint action of the Air Force and Navy Departments as the Air Force-Navy standard for this product. This drawing represents all essential standard drawings for the mass product and shall become obsolete for the procurement of conventional supplies, or for use in new design, not later than 8 months after the latest date of approval above.

This drawing was approved by joint action of the Air Force and Navy Departments as the Air Force-Navy standard for this product. This drawing represents all essential standard drawings for the mass product and shall become obsolete for the procurement of conventional supplies, or for use in new design, not later than 8 months after the latest date of approval above.

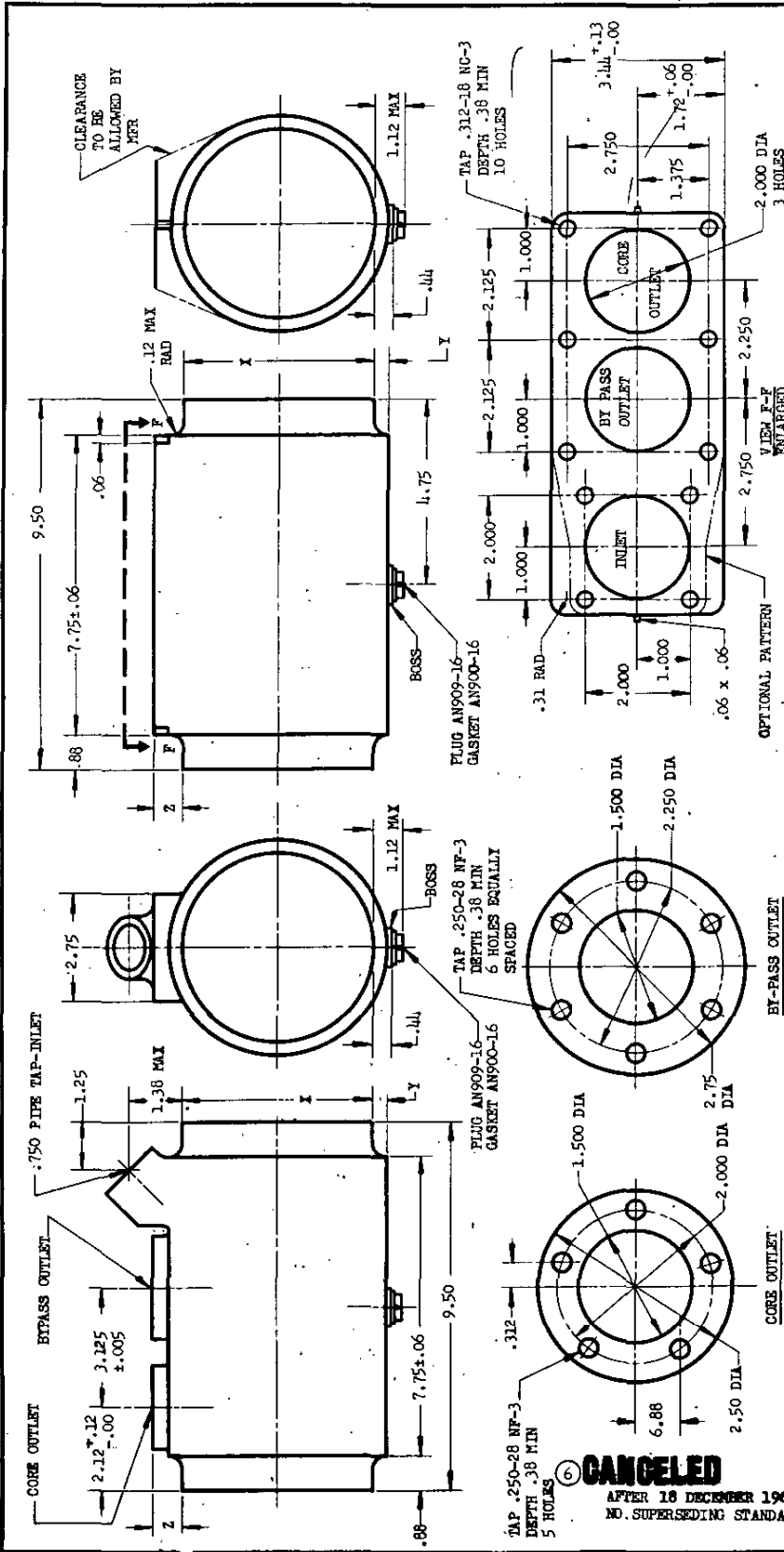

AN PART NO.	WT MAX LB	AN PART NO.	WT MAX LB	DIMENSIONS	
				X±.06 DIA	Y±.06 Z±.06
AN4080-9A	26.2	AN4080-9B	30.0	9	.38 .75
AN4080-10A	31.2	AN4080-10B	36.2	10	.38 .75
AN4080-11A	37.0	AN4080-11B	42.6	11	.38 .75
AN4080-12A	43.0	AN4080-12B	49.7	12	.38 .75
AN4080-13A	50.3	AN4080-13B	58.1	13	.38 .75
AN4080-14A	56.5	AN4080-14B	65.1	14	.63 1.00
AN4080-15A	63.0	AN4080-15B	73.8	15	.63 1.00
AN4080-16A	72.0	AN4080-16B	82.0	16	.63 1.00
AN4080-17A	80.0	AN4080-17B	91.0	17	.63 1.00
AN4080-18A	88.0	AN4080-18B	100.0	18	.63 1.00
AN4080-19A	97.5	AN4080-19B	110.0	19	.75 1.25
AN4080-20A	106.0	AN4080-20B	120.0	20	.75 1.25

AN PART NO.	WT MAX LB	AN PART NO.	WT MAX LB	DIMENSIONS	
				X±.06 DIA	Y±.06 Z±.06
AN4080-5A	11.1	AN4080-5B	12.5	5	.38 .75
AN4080-6A	11.1	AN4080-6B	16.1	6	.38 .75
AN4080-7A	17.9	AN4080-7B	20.3	7	.38 .75
AN4080-8A	21.9	AN4080-8B	25.9	8	.38 .75

INACTIVE FOR DESIGN AFTER 1 JUL 1949. NO SUPERSEDING AN STANDARD.
 FOR DESIGNATION AND APPLICATION OF IRABLING STATUS NOTE SEE ANA BULLETIN NO. 337.
 A AFTER DASH NUMBER INDICATES COOLER CONTAINING TUBES AN4081-1, AN4081-2.
 DIMENSIONS IN INCHES. UNLESS OTHERWISE SPECIFIED, TOLERANCES: TWO PLACE DECIMALS ±.03. THREE PLACE DECIMALS ±.005, ANGLES ±1/2°.

PROCUREMENT SPECIFICATION
 AN-C-75

AIR FORCE-NAVY AERONAUTICAL STANDARD
 COOLER - ROUND, COPPER, OIL

AN4080

APPROVED 15 Jul 42 REVISED 22 Dec 42 15 May 43 13 Apr 44 26 Aug 44 1 Jul 49 18 Dec 64