

[INCH-POUND]
 AN4052 Rev 8
 13 December 2013
 SUPERSEDING
 AN4052 Rev 7
 10 June 1987

DETAIL SPECIFICATION SHEET

COULPING, SHAFT, RIGID

Inactive for new design
 after 22 January 1999

This specification is approved for use by all Departments and Agencies of the Department of Defense

The requirements for acquiring the product described herein shall consist of this specification sheet.

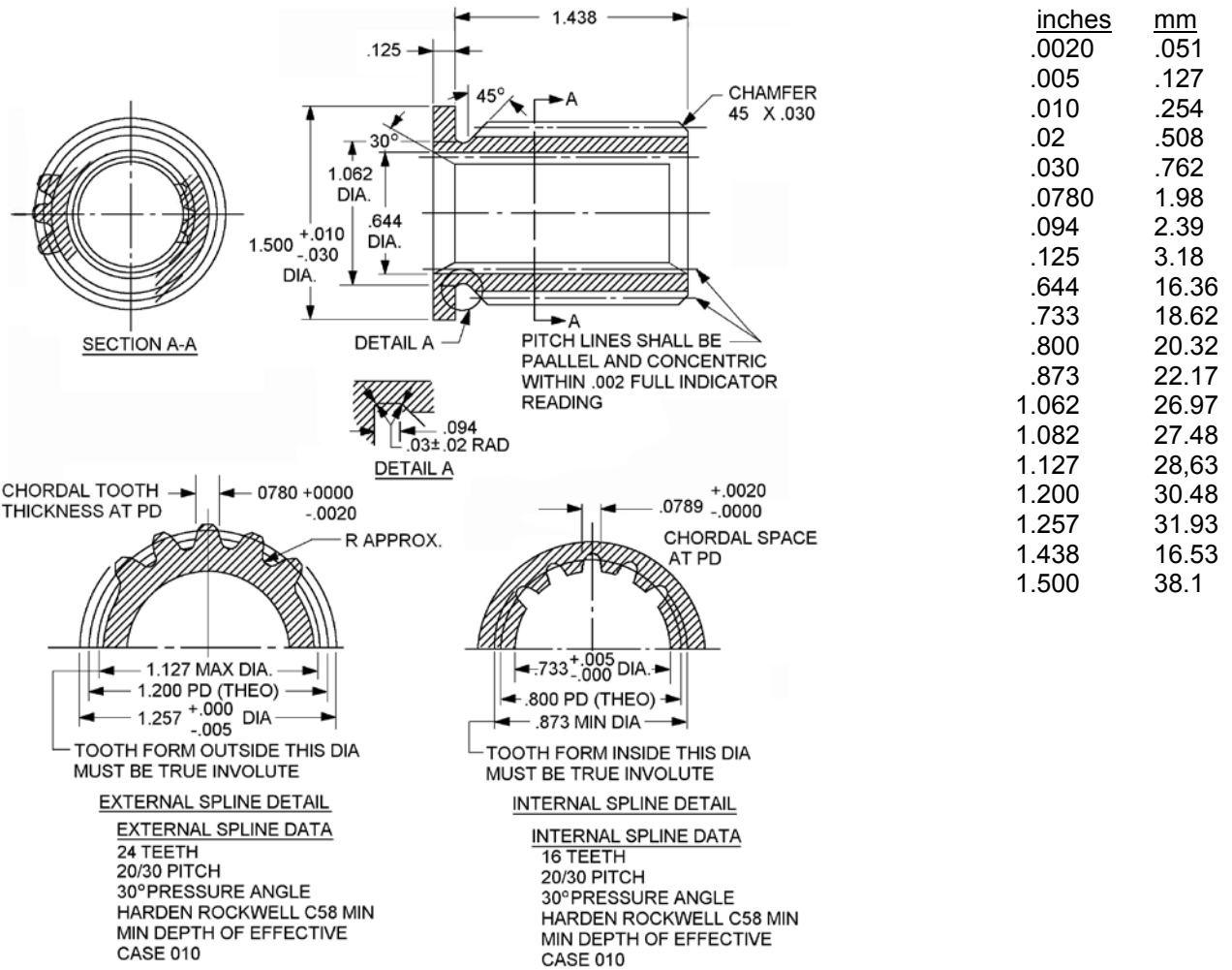

FIGURE 1. Coupling, Shaft, rigid.

AN4052 Rev 8

NOTES:

1. Dimensions are in inches.
2. Metric equivalents are given for information only.
3. Break sharp edges and remove all hanging burrs and slivers.
4. Unless otherwise noted tolerances shall be $\pm .010$ inches (0.254mm) and angles ± 2 .

Part or Identifying Number (PIN): The PIN consists of the letter "AN" the specification sheet number, and a dash number. AN4052-1

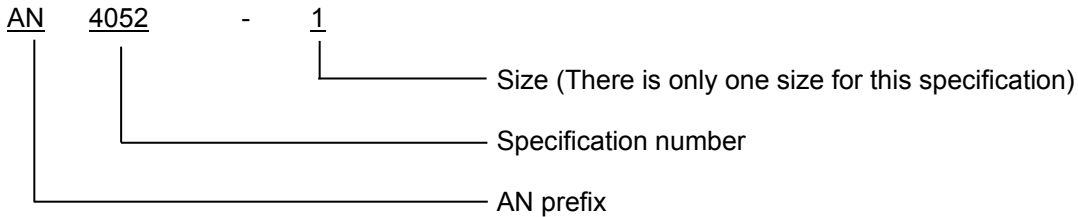

Material: Chrome-nickel-molybdenum steel in accordance with SAE-AMS6274 or chrome-nickel-molybdenum steel aluminum in accordance with SAE-AMS6470 or SAE-AMS6272.

Order of precedence. Unless otherwise noted herein or in the contract, in the event of a conflict between the text of this document and the references cited herein, the text of this document takes precedence. Nothing in this document, however, supersedes applicable laws and regulations unless a specific exemption has been obtained.

Referenced documents shall be of the issue in effect on date of invitations for bid.

Changes from previous issue. Marginal notations are not used in this revision to identify changes with respect to previous issue due to the extensiveness of the changes.

Referenced documents: This document references the following documents:

SAE-AMS6274
SAE-AMS6470
SAE-AMS6472

AN4052 Rev 8

CONCLUDING MATERIAL

MILITARY INTERESTS

Custodians:

Army - AV
Navy - AS
Air Force - 99
DLA - CC

Preparing activity:
DLA - CC

Project 3010-2013-001

Review activities:

Army-MI
Navy – SA
Air Force - 71

NOTE: The activities listed above were interested in this document as of the date of this document. Since organizations and responsibilities can change, you should verify the currency of the information above using the ASSIST Online database at <https://assist.dla.mil/>.