

USER SYMBOLS:  
NAVY - MC  
ARMY - MU

REVISOR SYMBOLS:  
USAF - 80  
ARMY - AV

MARK MILITARY PART NO.  
EITHER PLACE

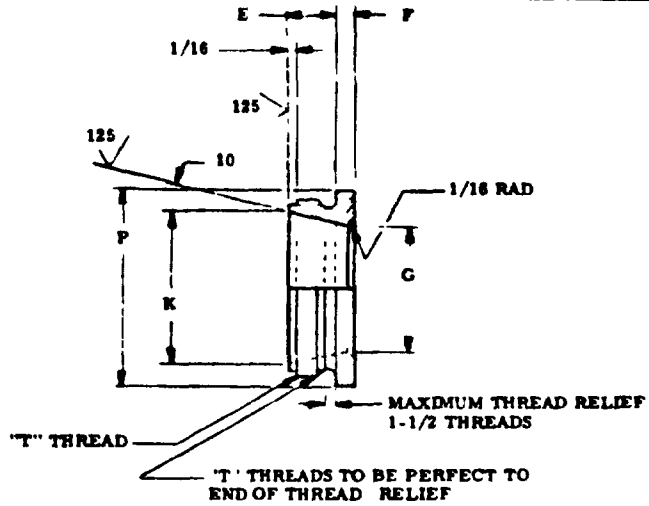
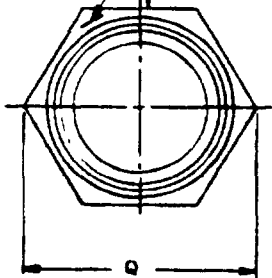

\*Delete/revise information in current ed of the date of this document  
 Per future coordination of changes in this document, draft circulation  
 should be based on the information in the current 009155

The military standard is approved for use by all Departments  
 & Agencies of the Department of Defense. Requests for all new  
 engineering and design applications and for reprints use shall  
 be made from this document.

AN PART NO	CONDUIT SIZE	T THREAD	E	F	G DIA	K DIA	P	Q APPROX
AN3056-3	3/16	5000-28 UNEF-2A	3/8	1/8	198	332	11/16	51/64
-4	1/4	8250-24 NEF-2A	3/8	1/8	260	394	13/16	15 16
-6	3/8	7500-20 UNEF-2A	3/8	1/8	385	519	15/16	1-3/32
-8	1/2	8750-20 UNEF-2A	3/8	3/16	510	669	1-1/16	1-15/64
-10	5/8	1 0000-20 UNEF-2A	3/8	3/16	635	794	1 1/4	1-7/16
-12	3/4	1 1875-18 NEF-2A	3/8	3/16	760	929	1-3/8	1-19/32
-16	1	1 4375-18 NEF-2A	1/2	3/16	1 010	1 214	1-5/8	1 7/8
-20	1-1/4	1 7500-18 NS-2A	1/2	3/16	1 261	1 469	2	2-5/16
-24	1-1/2	2 0000-18 NS-2A	1/2	3/16	1 511	1 724	2-3/16	2-17/32
-28	1-3/4	2 2500-16 UN-2A	1/2	1/4	1 761	1 976	2-7/16	2-13/16
-32	2	2 5000-16 UN-2A	9/16	1/4	2 011	2 229	2 13/16	3-1/4
AN3056-40	2-1/2	3 0000-16 UN-2A	5/8	1/4	2 512	2 744	3-3/8	3-57/64

**NOTES**

- MATERIAL ALUMINUM ALLOY QQ-A-225/5 (2017-T4) QQ-A-801 CLASS 4 OR QQ-A-250/4 OR COMMERCIAL GRADE SUITABLE TO PROCURING ACTIVITY
- SURFACE TEXTURE THE SURFACE TEXTURE SHALL BE IN ACCORDANCE WITH ANSI B46 1 CADMIUM PLATE, QQ-P-416, TYPE II, CLASS 2
- REMOVE ALL BURRS AND SHARP EDGES
- THREADS TO BE IN ACCORDANCE WITH MIL-S-7742, EXCEPT 1 7500-18 NS-2A AND 2,0000-18 NS-2A WHICH SHALL BE IN ACCORDANCE WITH AMERICAN NATIONAL STANDARDS INSTITUTE B1.1
- DIMENSIONS IN INCHES (" LESS OTHERWISE SPECIFIED, TOLERANCES FRACTIONS : 1/64 DECIMALS : 005 ANGLES : 1/2"

REFERENCED DOCUMENTS SHALL BE OF THE ISSUE IN EFFECT ON DATE OF INVITATIONS FOR BID

⑥ STANDARD REVISED AND REDRAWN

P A NAVY - AS Other Code  USAF - 85 ARMY - EL	<b>AERONAUTICAL STANDARD</b>	<b>AN3056</b>
	ADAPTER, ELECTRICAL CONDUIT, RIGID TO FLEXIBLE	
PROCUREMENT SPECIFICATION NONE	SUPERSEDES	SHEET 1 OF 1

APPROVED 23 MAR 40 REVISED ⑥ 31 JULY 1974

STANDARDIZATION DOCUMENT IMPROVEMENT PROPOSAL		OMB Approval No. 22-R255
<p>INSTRUCTIONS. The purpose of this form is to solicit beneficial comments which will help achieve procurement of suitable products at reasonable cost and minimum delay, or will otherwise enhance use of the document. DoD contractors, government activities, or manufacturers/vendors who are prospective suppliers of the product are invited to submit comments to the government. Fold on lines on reverse side, staple in corner, and send to preparing activity. Comments submitted on this form do not constitute or imply authorization to waive any portion of the referenced document(s) or to amend contractual requirements. Attach any pertinent data which may be of use in improving this document. If there are additional papers, attach to form and place both in an envelope addressed to preparing activity</p>		
DOCUMENT IDENTIFIER AND TITLE    AN3056 (6) ADAPTER, ELECTRICAL CONDUIT, RIGID TO FLEXIBLE		
NAME OF ORGANIZATION AND ADDRESS	CONTRACT NUMBER	
	MATERIAL PROCURED UNDER A <input type="checkbox"/> DIRECT GOVERNMENT CONTRACT <input type="checkbox"/> SUBCONTRACT	
<p>1 HAS ANY PART OF THE DOCUMENT CREATED PROBLEMS OR REQUIRED INTERPRETATION IN PROCUREMENT USE? A. GIVE PARAGRAPH NUMBER AND WORDING</p> <p>B. RECOMMENDATIONS FOR CORRECTING THE DEFICIENCIES</p>		
2. COMMENTS ON ANY DOCUMENT REQUIREMENT CONSIDERED TOO RIGID		
<p>3 IS THE DOCUMENT RESTRICTIVE? <input type="checkbox"/> YES    <input type="checkbox"/> NO (If "Yes", in what way?)</p>		
4 REMARKS		
SUBMITTED BY (Printed or typed name and address - Optional)		TELEPHONE NO
		DATE

FOLD

DEPARTMENT OF THE NAVY  
Naval Air Engineering Center  
Philadelphia, PA 19112

POSTAGE AND FEES PAID  
DEPARTMENT OF THE NAVY  
DOD 316



OFFICIAL BUSINESS

Engineering Specifications and Standards Department (Code ES)  
Naval Air Engineering Center  
Philadelphia, PA 19112

FOLD