

(a) AN PART NUMBER

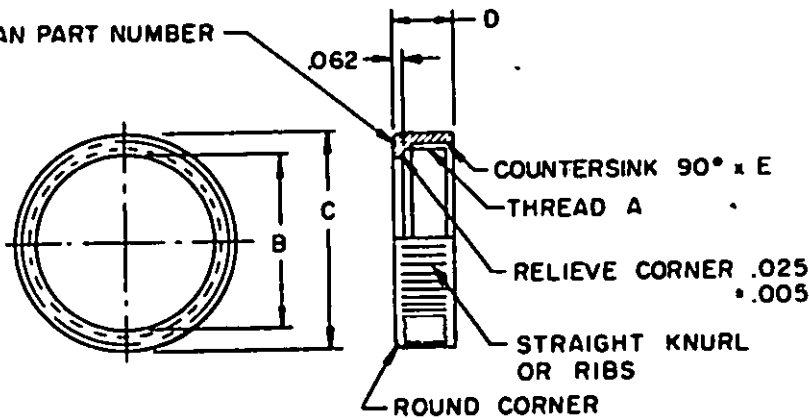

AN PART NO.	CONDUIT SIZE	THREAD A	B +.005	C +.047	D	E
AN3054-3	.188	.500-28 UNEF-2B	.396	.625	.438	.500
AN3054-4	.250	.625-24 NEF -2B	.458	.750	.438	.625
AN3054-5	.312	.688-24 NS -2B	.458	.781	.438	.688
AN3054-6	.375	.750-20 UNEF-2B	.583	.875	.438	.750
AN3054-8	.500	.875-20 UNEF-2B	.708	1.031	.438	.875
AN3054-10	.625	1.000-20 UNEF-2B	.833	1.156	.438	1.000
AN3054-12	.750	1.188-18 NEF -2B	.993	1.344	.438	1.188
AN3054-16	1.000	1.438-18 NEF -2B	1.278	1.594	.438	1.438
AN3054-20	1.250	1.750-18 NS -2B	1.533	1.906	.500	1.750
AN3054-24	1.500	2.000-18 NS -2B	1.788	2.156	.562	2.000
AN3054-28	1.750	2.250-16 UN -2B	2.040	2.406	.562	2.250
AN3054-32	2.000	2.500-16 UN -2B	2.293	2.656	.625	2.500
AN3054-40	2.500	3.000-16 UN -2B	2.808	3.156	.688	3.000

Threads to be in accordance with specification MIL-S-7742, refer to Table I for 1.750-18 NS-2B and 2.000-18 NS-2B. Threads to be perfect to within .094 inch from bottom. No thread relief at inner end permitted.

Material: Aluminum alloy, specification QQ-A-225/5, condition T4, or specification QQ-A-225/3, Tempor T3; specification QQ-A-591 or commercial grade diecastings suitable to the procuring activity; specification QQ-A-250/4, Heat-treat after drawing in accordance with specification MIL-H-6088.

Finish: Cadmium plate per MIL-C-5015. Remove all burrs and sharp edges.

Unless otherwise specified, dimensions are in inches, tolerances are + .016.

(a) Optional marking: Roll AN Part Number in the center of knurled portion.

ⓑ ENTIRE STANDARD REVISED

P.A. AF 85 Other Cust:	INTERNATIONAL INTEREST	TITLE NUT, COUPLING, ELECTRICAL CONDUIT	MILITARY STANDARD AN3054
Procurement Specifications NONE	SUPERSEDES:	NONE	SHEET OF

REVIEWER ACTIVITIES: AF 99

This military standard is approved by the HQ AFCLC/LOIE Department of the A.F. and shall be used by that activity. All other military activities are required to employ this standard where suitable.

APPROVED 2 FEB 40 REVISED ⓑ