

AIR FORCE (A) THIS DRAWING WAS APPROVED BY THE AIR FORCE AND NAVY DEPARTMENTS IN JANUARY 1945. THE DRAWING IS FOR REFERENCE AND STOCK PURPOSES ONLY. FOR MANUFACTURING DETAILS, SEE ANA STANDARD ISSUE OF DRAWING NAF 48379. DIMENSIONS IN INCHES. DIMENSIONS ARE FOR REFERENCE ONLY.

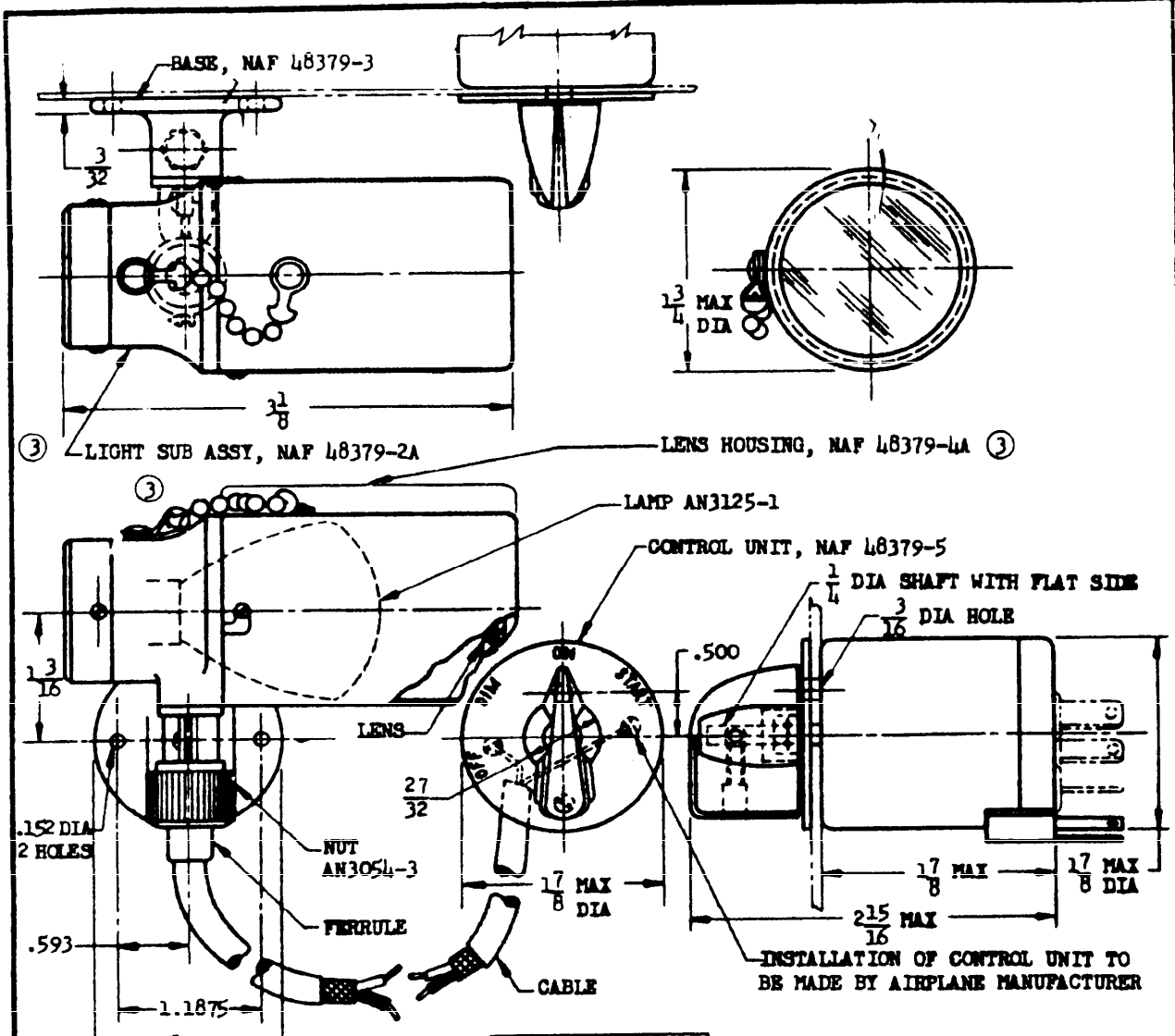

AN PART NO.
(a) AN3038-1
(b) <del>AN3038-2</del>
(b) AN3038-2A

- ③ (a) PREVIOUS PART NUMBER AN3038-1 (NOT SHOWN), COVERING LIGHT ASSEMBLY WITH VISIBLE LIGHT FEATURE, INACTIVE FOR DESIGN AFTER 31 MARCH 1945.
- ③ (b) PREVIOUS PART NUMBER AN3038-2 INACTIVE FOR DESIGN AFTER 24 JAN 1949 AN3038-2A REPLACES AND IS INTERCHANGEABLE WITH AN3038-2.

③ FOR DEFINITION AND APPLICATION OF DRAWING STATUS NOTES, SEE ANA BULLETIN NO. 337. LIGHT SUB ASSEMBLY IS COMPLETE WITH LENS HOUSING, LAMP, NUT, FERRULE, AND CABLE, WITHOUT BASE.

THIS DRAWING IS FOR REFERENCE AND STOCK PURPOSES ONLY. FOR MANUFACTURING DETAILS, SEE ANA STANDARD ISSUE OF DRAWING NAF 48379.

DIMENSIONS IN INCHES. DIMENSIONS ARE FOR REFERENCE ONLY.

PROCUREMENT SPECIFICATION  AN-L-23	<b>AIR FORCE-NAVY AERONAUTICAL STANDARD</b>  LIGHT ASSEMBLY - ULTRAVIOLET FLUORESCENT COCKPIT	AN3038
--	---	--------

SUPERSUCKERS  
 DRAWING NAF 1192

APPROVED 15 Feb 43 REVISED ① 31 Mar 45 ② 2 Aug 45 ③ 24 Jan 49