

INCH-POUND

AN929 Rev 14
 29 August 2017
 SUPERSEDING
 AN929 Rev 13
 w/AMENDMENT 2
 7 August 2014

DETAIL SPECIFICATION SHEET

CAP INSERT, ASSEMBLY, PRESSURE SEAL,
 FLARED TUBE FITTING

This specification is approved for use by all Departments and Agencies
 of the Department of Defense.

The requirements for acquiring the product described herein shall consist of this specification sheet and
 SAE-AS4841.

Cap dimensions and configuration, see figure 1. Cap and nut assembly, see figure 2.

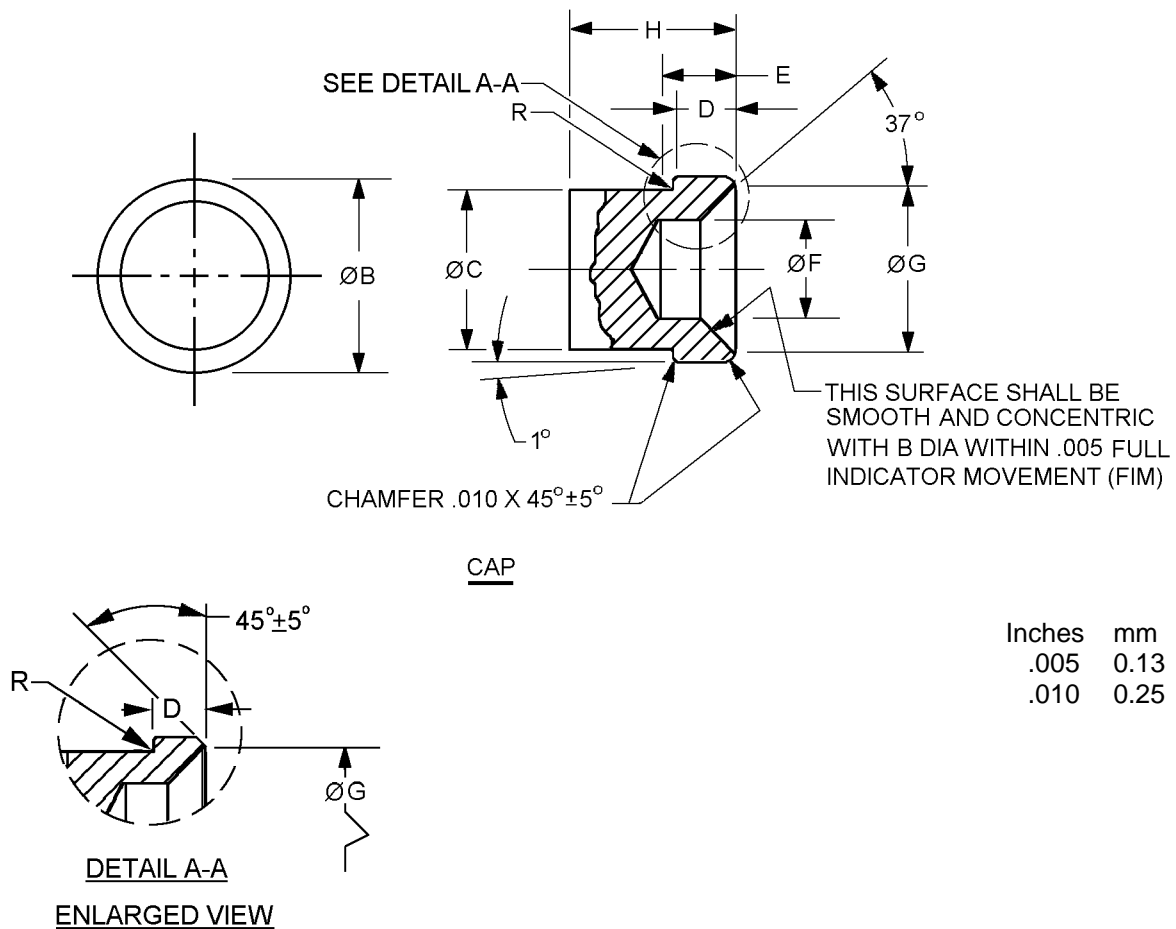

FIGURE 1. Cap dimensions and configuration.



AN929 Rev 14

Dash number	Tube OD inches (mm)	B dia. inches (mm) +.000 -.003 (0.08)	C dia. inches (mm)	D inches (mm)	E inches (mm)
-2	.125 (3.18)	.263 (6.68)	.156 (3.96)	.156 (3.96)	.125 (3.18)
-3	.188 (4.78)	.325 (8.26)	.219 (5.56)	.219 (5.56)	
-4	.250 (6.35)	.378 (9.60)	.281 (7.14)	.203 (5.16)	
-5	.313 (7.95)	.441 (11.20)	.344 (8.74)	.219 (5.56)	.141 (3.58)
-6	.375 (9.53)	.503 (12.78)	.422 (10.72)	.266 (6.76)	.156 (3.96)
-8	.500 (12.70)	.683 (17.35)	.547 (13.89)	.313 (7.95)	.172 (4.37)
-10	.625 (15.88)	.799 (20.30)	.672 (17.07)	.281 (7.14)	.250 (6.35)
-12	.750 (19.05)	.974 (24.74)	.813 (20.65)		.313 (7.95)
-16	1.000 (25.40)	1.224 (31.09)	1.063 (27.00)	.297 (7.54)	
-20	1.250 (31.75)	1.536 (39.01)	1.328 (33.73)	.375 (9.53)	
-24	1.500 (38.10)	1.786 (45.36)	1.594 (40.49)	.406 (10.31)	.375 (9.53)
-28	1.750 (44.45)	2.161 (54.89)	1.875 (47.63)	.500 (12.70)	
-32	2.000 (50.80)	2.411 (61.24)	2.141 (54.38)	.578 (14.68)	.500 (12.70)
-40	2.500 (63.50)	2.911 (73.94)	2.641 (67.08)	.625 (15.88)	.688 (17.48)
-48	3.000 (76.20)	3.411 (86.64)	3.156 (80.16)	.688 (17.48)	

Dash number	F dia.	G dia. inches (mm) +.000 -.005 (0.13)	H inches (mm)	R radius max inches (mm)
-2	.094 (2.39)	.218 (5.54)	.531 (13.49)	.005 (0.13)
-3	.156 (3.96)	.250 (6.35)		
-4	.172 (4.37)	.300 (7.62)		
-5	.234 (5.94)	.360 (9.14)	.563 (14.30)	.010 (0.25)
-6	.297 (7.54)	.440 (11.18)	.625 (15.88)	
-8	.391 (9.93)	.575 (14.61)	.750 (19.05)	
-10	.438 (11.13)	.685 (17.40)		
-12	.563 (14.30)	.885 (22.48)	.875 (22.23)	
-16	.813 (20.65)	1.103 (28.02)		
-20	1.078 (27.38)	1.413 (35.89)	1.000 (25.40)	.015 (0.38)
-24	1.313 (33.35)	1.661 (42.19)	1.125 (28.58)	
-28	1.547 (39.29)	2.034 (51.66)	1.375 (34.93)	
-32	1.781 (45.24)	2.284 (58.01)	1.438 (36.53)	
-40	2.000 (50.80)	2.784 (70.71)	1.750 (44.45)	
-48	2.500 (63.50)	3.284 (83.41)	1.813 (46.05)	

NOTES:

- Dimensions are in inches.
- Metric equivalents are given for information only.
- Fittings shall be free of all burrs and slivers.
- Unless otherwise specified, tolerances for three point decimals ± 0.010 inch (0.25 mm).
- For design features purposes, this standard takes precedence over documents referenced herein.

FIGURE 1. Cap dimensions and configuration - Continued.

AN929 Rev 14

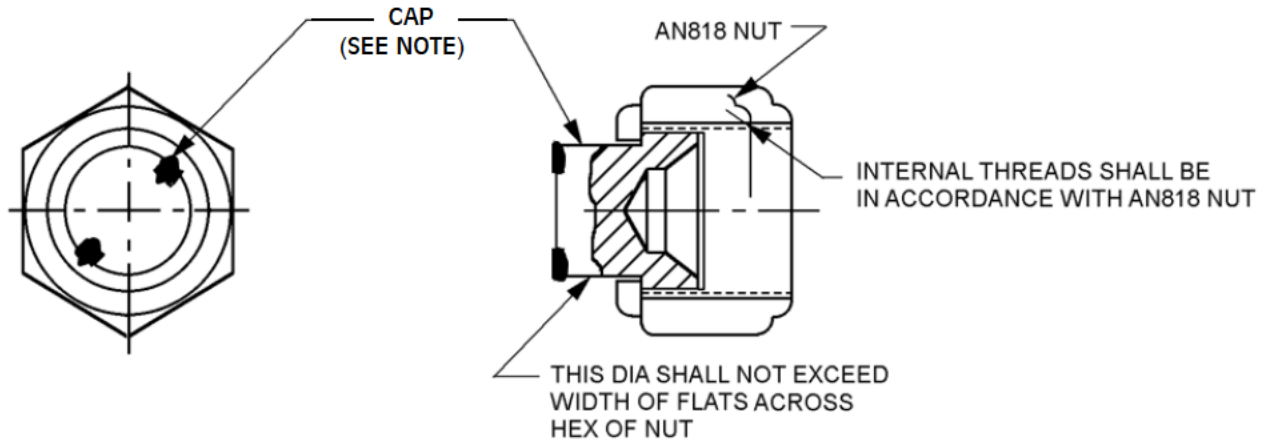

NOTE: Cap shall be movable and permanently secured to the nut to prevent assembly from coming apart, such as mechanical staking. The method used to prevent the movable cap from falling out of the nut is the manufacturer's option. Other methods may be used upon approval by the Preparing Activity. A physical and permanent retention method shall be present. See figure 4 for examples of approved methods.

FIGURE 2. Cap and nut assembly.

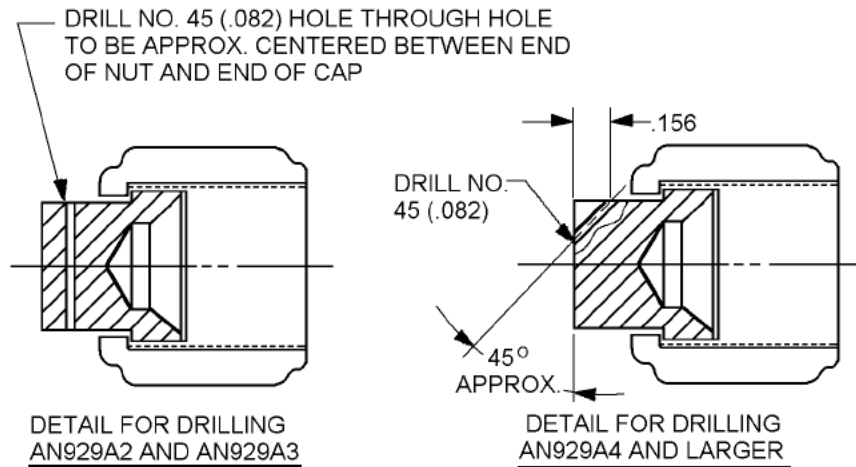

Inches	mm
.005	0.13
.082	2.08
.156	3.96

FIGURE 3. Cap assembly, safety chain configurations.

AN929 Rev 14

REQUIREMENTS:

Dimensions and configurations: See figures 1, 2, and 3.

The Part or Identifying Number (PIN) represents a 2-piece assembly consisting of an AN818 nut and a permanently attached movable cap insert as specified herein and as shown on figure 2.

Material: See table I herein, procurement specification SAE-AS4841.

TABLE I. Material cap assembly.

Cap insert assembly AN929			Nut AN818 <u>2/</u>		
Material designator	Material	Alloy	Material designator	Material	Alloy
F	Steel	4130 or 4140	Blank	Steel	4130 or 4140
J	CRES	304	J	CRES	304
K	CRES	316	K	CRES	316
S	CRES	347	J or K	CRES	304 or 316
T <u>1/</u>	Titanium	6Al-4V	T	Titanium	6Al-4V
W	Aluminum	7075-T73	W	Aluminum	7075-T73

1/ Not for use with oxygen systems.

2/ Material designator for manufacturers use only to determine proper AN818 nut to use for the cap insert assembly.

Finish: See SAE-AS4841.

PIN: The PIN consists of the AN prefix, specification sheet number, dash or "A" for cap drilled for safety chain, blank or "L" for nut drilled with lock wire, number for assembly size, and a letter for material designator.

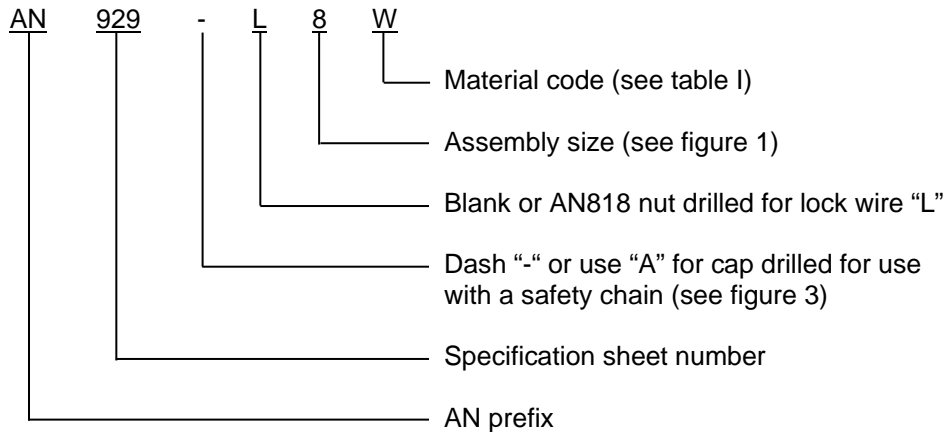

PIN Examples:

AN929-8W identifies a cap assembly .500 inch (tube), 7075-T73 aluminum.

AN929-L8J identifies a cap assembly .500 inch (tube), AN818 nut drilled for lock wire, CRES 304.

AN929A8S identifies a cap assembly .500 inch (tube), cap drilled for attachment of safety chain, CRES 347.

AN929AL8J identifies a cap assembly .500 inch (tube), cap drilled for use with a safety chain, and AN818 nut drilled for lock wire, CRES 304.

AN929 Rev 14

Supersession data: The blank material designator for aluminum alloys 2014 and 2024 in table II have been replaced by a "W" material designator for aluminum alloy 7075-T73 due to stress corrosion cracking aluminum alloys 2014 and 2024.

TABLE II. Supersession data.

Cancelled AN929 PIN	Replacement AN929 PIN	Cancelled AN929 PIN	Replacement AN929 PIN
AN929-2	AN929-2W	AN929-16	AN929-16W
AN929-L2	AN929-L2W	AN929-L16	AN929-L16W
AN929A2	AN929A2W	AN929A16	AN929A16W
AN929AL2	AN929AL2W	AN929AL16	AN929AL16W
AN929-3	AN929-3W	AN929-20	AN929-20W
AN929-L3	AN929-L3W	AN929-L20	AN929-L20W
AN929A3	AN929A3W	AN929A20	AN929A20W
AN929AL3	AN929AL3W	AN929AL20	AN929AL20W
AN929-4	AN929-4W	AN929-24	AN929-24W
AN929-L4	AN929-L4W	AN929-L24	AN929-L24W
AN929A4	AN929A4W	AN929A24	AN929A24W
AN929AL4	AN929AL4W	AN929AL24	AN929AL24W
AN929-5	AN929-5W	AN929-28	AN929-28W
AN929-L5	AN929-L5W	AN929-L28	AN929-L28W
AN929A5	AN929A5W	AN929A28	AN929A28W
AN929AL5	AN929AL5W	AN929AL28	AN929AL28W
AN929-6	AN929-6W	AN929-32	AN929-32W
AN929-L6	AN929-L6W	AN929-L32	AN929-L32W
AN929A6	AN929A6W	AN929A32	AN929A32W
AN929AL6	AN929AL6W	AN929AL32	AN929AL32W
AN929-8	AN929-8W	AN929-40	AN929-40W
AN929-L8	AN929-L8W	AN929-L40	AN929-L40W
AN929A8	AN929A8W	AN929A40	AN929A40W
AN929AL8	AN929AL8W	AN929AL40	AN929AL40W
AN929-10	AN929-10W	AN929-48	AN929-48W
AN929-L10	AN929-L10W	AN929-L48	AN929-L48W
AN929A10	AN929A10W	AN929A48	AN929A48W
AN929AL10	AN929AL10W	AN929AL48	AN929AL48W
AN929-12	AN929-12W		
AN929-L12	AN929-L12W		
AN929A12	AN929A12W		
AN929AL12	AN929AL12W		

AN929 Rev 14



FIGURE 4. Examples of approved methods of cap retention.

Changes from previous issue. The margins of this specification are marked with vertical lines to indicate where changes from the previous issue were made. This was done as a convenience only and the Government assumes no liability whatsoever for any inaccuracies in these notations. Bidders and contractors are cautioned to evaluate the requirements of this document based on the entire content irrespective of the marginal notations and relationship to the previous issue.

Referenced documents. In addition to SAE-AS4841, this document references AN818.

CONCLUDING MATERIAL

Custodians:
Navy - AS
Air Force - 99
DLA - CC

Preparing activity:
DLA - CC

(Project 4730-2017-081)

Review activity:
Air Force - 71

NOTE: The activities listed above were interested in this document as of the date of this document. Since organizations and responsibilities can change, you should verify the currency of the information above using the ASSIST Online database at <https://assist.dla.mil>.