

INCH-POUND

AN924 Rev 12
 14 June 2012
 SUPERSEDING
 AN924 Rev 11
 21 March 1979

DETAIL SPECIFICATION SHEET

NUT, TUBE, BULKHEAD AND UNIVERSAL FITTING

Reinstated after 14 June 2012. Inactive for new design.
 For new design, use SAE-AS5178.

This specification is approved for use by all Departments and
 Agencies of the Department of Defense.

The requirements for acquiring the product described herein shall consist of this specification sheet and
 SAE-AS4842.

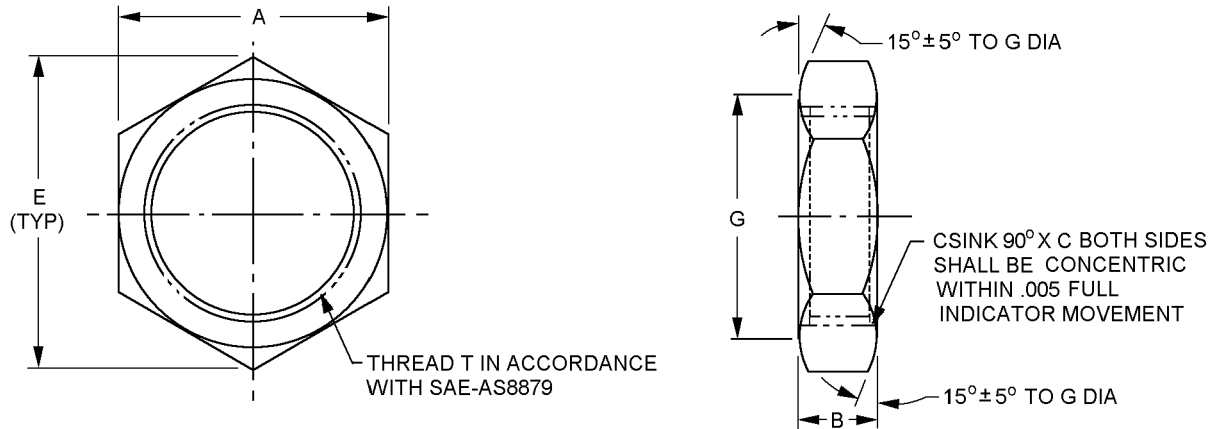

Inch	mm
.005	0.13

FIGURE 1. Tube nut dimensions and configurations.

AN924 Rev 12

Dash number	Tubing OD	Thread T (Ref) SAE-AS8879	A inches (mm)		B inches (mm)
2	.125	.3125-24UNJF-3B	.563 (14.30)	+0.03 (0.08) -0.04 (0.10)	.219 (5.56)
3	.188	.3750-24UNJF-3B	.625 (15.88)		.219 (5.56)
4	.250	.4375-20UNJF-3B	.688 (17.48)		.250 (6.35)
5	.313	.5000-20UNJF-3B	.750 (19.05)		.250 (6.35)
6	.375	.3750-18UNJF-3B	.813 (20.65)		.266 (6.76)
8	.500	.7500-16UNJF-3B	1.000 (25.40)		.313 (7.95)
10	.628	.8750-14UNJF-3B	1.125 (28.58)		.359 (9.12)
12	.750	1.0625-12UNJ-3B	1.375 (34.93)		.406 (10.31)
16	1.000	1.3125-12UNJ-3B	1.625 (41.28)		
20	1.250	1.6250-12UNJ-3B	1.938 (49.23)		
24	1.500	1.875-12UNJ-3B	2.188 (55.58)		
28	1.750	2.250-12UNJ-3B	2.563 (65.10)		
32	2.000	2.500-12UNJ-3B	2.813 (71.45)		
40	2.500	3.000-12UNJ-3B	3.312 (84.12)		
48	3.500	3.500-12UNJ-3B	3.812 (96.82)		

Dash number	C Dia.	E Min.	G ± 0.10 (0.25) inches (mm)	H Max (see note 5) inches (mm)
2	.313 (7.95)	.629 (15.98)	.500 (12.70)	.005 (0.13)
3	.375 (9.53)	.699 (17.75)	.562 (14.27)	
4	.438 (11.13)	.771 (19.58)	.625 (15.88)	
5	.500 (12.70)	.842 (21.39)	.687 (17.45)	
6	.563 (14.30)	.914 (23.22)	.750 (19.05)	
8	.750 (19.05)	1.127 (28.63)	.937 (2.80)	
10	.875 (22.23)	1.270 (32.26)	1.052 (26.72)	
12	1.063 (27.00)	1.555 (39.50)	1.274 (32.36)	
16	1.313 (33.35)	1.827 (46.41)	1.524 (38.71)	
20	1.625 (41.28)	2.184 (55.47)	1.838 (46.69)	
24	1.875 (47.63)	2.465 (62.61)	2.093 (53.16)	.008 (0.20)
28	2.250 (57.15)	2.892 (73.46)	2.468 (62.69)	
32	2.500 (63.50)	3.178 (80.72)	2.718 (69.04)	
40	3.000 (76.20)	3.747 (95.17)	3.218 (81.74)	
48	3.500 (88.90)	4.318 (109.68)	3.718 (94.44)	

NOTES:

1. Dimensions are in inches.
2. Metric equivalents are given for information only.
3. Unless otherwise specified tolerances are ± 0.016 inch (0.41 mm) angles $\pm 0.5^\circ$.
4. Break sharp edges and remove all hanging burrs and slivers.
5. Squareness between thread and face of hex shall not exceed H when measured at diameter G, both sides.
6. Machined surfaces shall be finished to 125 μ m Ra, forged surfaces shall be 250 μ m Ra, unless otherwise specified on the figures. Surface finish shall be in accordance with ASME B46.1.
7. For design features purposes, this standard takes precedence over documents referenced herein.
8. Referenced documents shall be of the issue in effect on date of invitation for bid.

FIGURE 1. Tube nut dimensions and configurations - Continued.

AN924 Rev 12

REQUIREMENTS:

Dimensions and configuration shall be in accordance with figure 1.

Installation shall be in accordance with MS21344.

Materials and finishes shall be in accordance with SAE-AS4842, see table I for material code.

TABLE I. Material and code letters.

Code letter	Material
Blank	Copper alloy
J	CRES, type 304
K	CRES, type 316
R	CRES, type 321
T ^{1/}	Titanium
W	Aluminum alloy 7075-T73

^{1/} Not for use in oxygen systems.

Part or Identifying Number (PIN): The PIN consists of the letter "AN" the specification sheet number, a dash number for pipe thread size, and a material code letter. Unassigned PIN's shall not be used.

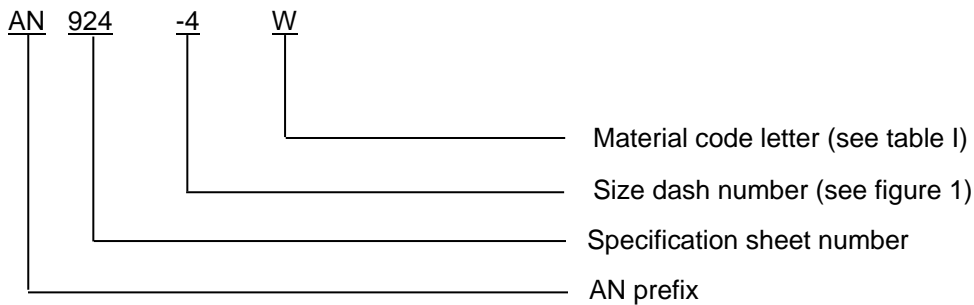

PIN example: AN924-4W indicates a tube nut, .4375-20UNJF-3B threads, aluminum alloy 7075-T73.

Marking: Part shall be impression stamped with the AN PIN, and include the manufacturers CAGE, name, or trademark on the hex side only.

Supersession data:

Due to stress corrosion cracking aluminum alloys 2014 and 2024 "D" designator has been replaced by aluminum alloy 7075 "W" designator example: AN924-4 use AN924-4W.

Metal cracking due to high temperatures CRES alloy 347 "S" designator has been replaced by CRES alloy 321 "R" designator. Example: AN9244S use AN924-4R.

AN924 and MS24400 CRES nuts of like size are physically interchangeable; however MS24400 nuts coded C cannot always replace AN924 nuts coded J or K and MS24400 nuts coded S cannot always replace AN924 nuts coded S.

Table II provides a detailed cross-reference of AN924 PINs and replacement SAE-AS5178 PINs. Users are cautioned to evaluate replacements for their particular application.

AN924 Rev 12

CAUTION: The superseding information is valid as of the date of this specification and may be superseded by subsequent revisions of the superseding document.

TABLE II. AN924 to SAE- AS5178 cross-reference data. 1/

AN PIN	Tube Size	Replacement AN PIN	AS PIN
AN924-2	.125		AS5178-02
AN924-2D	.125	AN924-2W	AS5178W02
AN924-2J	.125		AS5178J02
AN924-2K	.125		AS5178K02
AN924-2S	.125	AN924-2R	AS5178S02
AN924-2T	.125		AS5178T02
AN924-2W	.125		AS5178W02
AN924-3	.188		AS5178-03
AN924-3D	.188	AN924-3W	AS5178W03
AN924-3J	.188		AS5178J03
AN924-3K	.188		AS5178K03
AN924-3S	.188	AN924-3R	AS5178S03
AN924-3T	.188		AS5178T03
AN924-3W	.188		AS5178W03
AN924-4	.250		AS5178-04
AN924-4D	.250	AN924-4W	AS5178W04
AN924-4J	.250		AS5178J04
AN924-4K	.250		AS5178K04
AN924-4S	.250	AN924-4R	AS5178S04
AN924-4T	.250		AS5178T04
AN924-4W	.250		AS5178W04
AN924-5	.312		AS5178-05
AN924-5D	.312	AN924-5W	AS5178W05
AN924-5J	.312		AS5178J05
AN924-5K	.312		AS5178K05
AN924-5S	.312	AN924-5R	AS5178S05
AN924-5T	.312		AS5178T05
AN924-5W	.312		AS5178W05
AN924-6	.375		AS5178-06
AN924-6D	.375	AN924-6W	AS5178W06
AN924-6J	.375		AS5178J06
AN924-6K	.375		AS5178K06
AN924-6S	.375	AN924-6R	AS5178S06
AN924-6T	.375		AS5178T06
AN924-6W	.375		AS5178W06

See note at end of table.

AN924 Rev 12

TABLE II. AN924 to SAE- AS5178 cross-reference data - Continued. 1/

AN PIN	Tube Size	Replacement AN PIN	AS PIN
AN924-8	.500		AS5178-08
AN924-8D	.500	AN924-8W	AS5178W08
AN924-8J	.500		AS5178J08
AN924-8K	.500		AS5178K08
AN924-8S	.500	AN924-8R	AS5178S08
AN924-8T	.500		AS5178T08
AN924-8W	.500		AS5178W08
AN924-10	.625		AS5178-10
AN924-10D	.625	AN924-10W	AS5178W10
AN924-10J	.625		AS5178J10
AN924-10K	.625		AS5178K10
AN924-10S	.625	AN924-10R	AS5178S10
AN924-10T	.625		AS5178T10
AN924-10W	.625		AS5178W10
AN924-12	.750		AS5178-12
AN924-12D	.750	AN924-12W	AS5178W12
AN924-12J	.750		AS5178J12
AN924-12K	.750		AS5178K12
AN924-12S	.750	AN924-12R	AS5178S12
AN924-12T	.750		AS5178T12
AN924-12W	.750		
AN924-16	1.000		AS5178-16
AN924-16D	1.000	AN924-16W	AS5178W16
AN924-16J	1.000		AS5178J16
AN924-16K	1.000		AS5178K16
AN924-16S	1.000	AN924-16R	AS5178S16
AN924-16T	1.000		AS5178T16
AN924-16W	1.000		AS5178W16
AN924-20	1.250		AS5178-20
AN924-20D	1.250	AN924-20W	AS5178W20
AN924-20J	1.250		AS5178J20
AN924-20K	1.250		AS5178K20
AN924-20S	1.250	AN924-20R	AS5178S20
AN924-20T	1.250		AS5178T20
AN924-20W	1.250		AS5178W20

See note at end of table.

AN924 Rev 12

TABLE II. AN924 to SAE- AS5178 cross-reference data - Continued. 1/

AN PIN	Tube Size	Replacement AN PIN	AS PIN
AN924-24	1.500		AS5178-24
AN924-24D	1.500	AN924-24W	AS5178D24
AN924-24J	1.500		AS5178J24
AN924-24K	1.500		AS5178K24
AN924-24S	1.500	AN924-24R	AS5178S24
AN924-24T	1.500		AS5178T24
AN924-24W	1.500		AS5178W24
AN924-28	1.750		AS5178-28
AN924-28D	1.750	AN924-28W	AS5178W28
AN924-28J	1.750		AS5178J28
AN924-28K	1.750		AS5178K28
AN924-28S	1.750	AN924-28R	AS5178R28
AN924-28T	1.750		AS5178T28
AN924-28W	1.750		AS5178W28
AN924-32	2.000		AS5178-32
AN924-32D	2.000	AN924-32W	AS5178W32
AN924-32J	2.000		AS5178J32
AN924-32K	2.000		AS5178K32
AN924-32S	2.000	AN924-32R	AS5178R32
AN924-32T	2.000		AS5178T32
AN924-32W	2.000		AS5178W32
AN924-40	2.500		AS5178-40
AN924-40D	2.500	AN924-40W	AS5178D40
AN924-40J	2.500		AS5178J40
AN924-40K	2.500		AS5178K40
AN924-40S	2.500	AN924-40R	AS5178S40
AN924-40T	2.500		AS5178T40
AN924-40W	2.500		AS5178W40
AN924-48	3.000		AS5178-48
AN924-48D	3.000	AN924-48W	AS5178D48
AN924-48J	3.000		AS5178J48
AN924-48K	3.000		AS5178K48
AN924-48S	3.000	AN924-48R	AS5178S48
AN924-48T	3.000		AS5178T48
AN924-48W	3.000		AS5178W48

1/ For new design use material designator R and W.

Changes from previous issues. Marginal notations are not used in this revision to identify changes with respect to the previous issue due to the extent of the changes.

AN924 Rev 12

Referenced documents. In addition to SAE-AS4842, this document references the following:

MS21344
ASME B46.1
SAE-AS5178
SAE-AS8879

CONCLUDING MATERIAL

Custodians:

Army - AV
Navy - AS
Air Force - 99
DLA - CC

Preparing activity:
DLA - CC

(Project 4730-2012-031)

Review activities:

Navy - SA
Air Force - 71

NOTE: The activities listed above were interested in this document as of the date of this document. Since organizations and responsibilities can change, you should verify the currency of the information above using the ASSIST Online database at <https://assist.dla.mil>.