

INCH-POUND

AN911 Rev 10
 19 July 2011
 SUPERSEDING
 AN911 Rev 9
 20 March 1979

DETAIL SPECIFICATION SHEET

NIPPLE, PIPE

Reinstated after 19 July 2011. Inactive for new design.
 For new design, use SAE-AS4860.

This specification is approved for use by all Departments and
 Agencies of the Department of Defense.

The requirements for acquiring the product described herein shall consist of this specification sheet and
 SAE-AS4842.

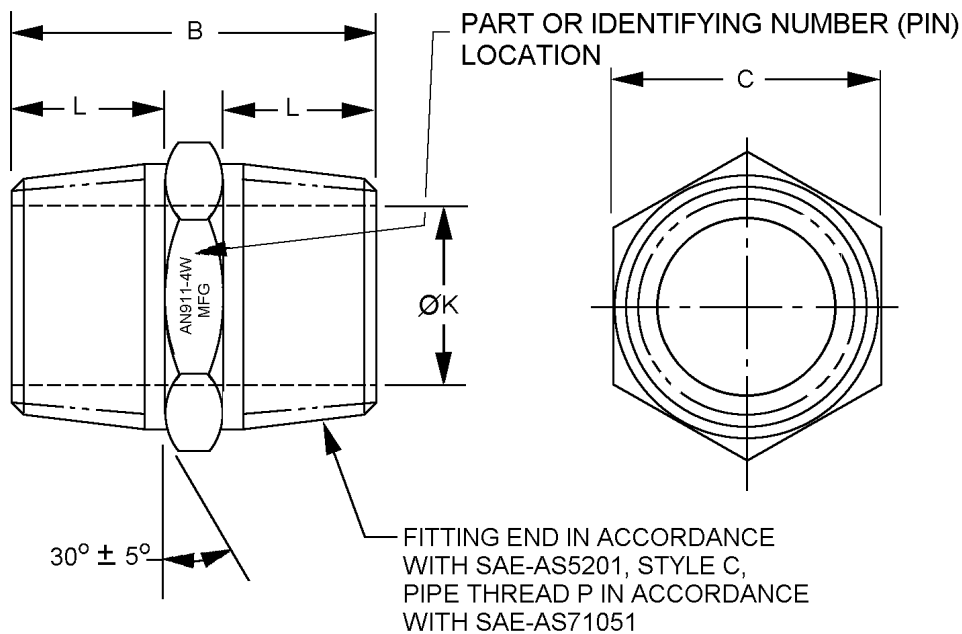

FIGURE 1. Nipple pipe dimensions and configurations.

AN911 Rev 10

Dash number pipe size	SAE- AS5201 size code	A Pipe thread ANPT SAE-AS71051	B +.031 (0.79) inches (mm)	C inches (mm)	
1	02	1/8-27	.969 (24.61)	.438 (11.130)	+0.003 (0.08) -.004 (0.10)
2	04	1/4-18	1.438 (36.52)	.625 (15.88)	±.004 (0.10)
3	06	3/8-18	1.469 (37.31)	.750 (19.05)	±.004 (0.10)
4	08	1/2-14	1.844 (46.84)	.938 (23.83)	±.004 (0.10)
6	12	3/4-14	1.906 (48.41)	1.125 (28.58)	±.005 (.013)
8	16	1-11 1/2	2.313 (58.75)	1.375 (34.93)	±.005 (0.13)
10	20	1/ 1/4-11 1/2	2.344 (59.54)	1.750 (44.45)	±.016 (0.41)

Dash number pipe size	K Dia. inches (mm)		L inches (mm)
1	.203 (5.16)	+0.003 (0.08) -.004 (0.10)	.391 (9.93)
2	.279 (7.09)	±.004 (0.10)	.594 (15.09)
3	.418 (10.62)	+0.006 (0.15) -.007 (0.18)	.594 (15.09)
4	.508 (12.90)	±.010 (0.25)	.766 (19.46)
6	.727 (18.47)	+0.009 (0.23) -.010 (0.25)	.781 (19.84)
8	.914 (23.22)	±.010 (0.25)	.969 (24.61)
10	1.256 (31.90)	±.008 (0.20)	.984 (24.99)

Dash number pipe size	Weight max lbs (kg)			
	Copper alloy	Al alloy	Steel, CRES	Ti alloy
1	.027 (0.01)	.009 (0.004)	.027 (0.012)	.015 (0.007)
2	.072 (0.03)	.024 (0.010)	.072 (0.033)	.040 (0.018)
3	.093 (0.04)	.031 (0.014)	.093 (0.042)	.051 (0.023)
4	.186 (0.08)	.062 (0.028)	.186 (0.084)	.102 (0.046)
6	.249 (0.11)	.083 (0.038)	.240 (0.109)	.137 (0.062)
8	.444 (0.20)	.148 (0.067)	.443 (0.196)	.245 (0.111)
10	.606 (0.27)	.202 (0.091)	.605 (0.274)	.334 (0.151)

NOTES:

- Dimensions are in inches.
- Metric equivalents are given for information only.
- Break sharp edges and remove all hanging burrs and slivers
- Machined surfaces shall be finished to 125µin Ra, forged surfaces shall be 250µin RA, unless otherwise specified on the figures. Surface finish shall be in accordance with ASME B46.1.
- For design features purposes, this standard takes precedence over documents referenced herein.
- Referenced documents shall be of the issue in effect on date of invitation for bid.

FIGURE 1. Nipple pipe dimensions and configurations - Continued.

AN911 Rev 10

REQUIREMENTS:

Dimensions and configuration shall be in accordance with figure 1.

Materials and finishes shall be in accordance with SAE-AS4842, see table I for material code.

TABLE I. Material and code letters.

Code letter	Material
Blank	Copper alloy
J	Corrosion resistant steel (CRES), type 304
K	CRES, type 316
R	CRES. Type 321
T	Titanium alloy 1/
W	Aluminum alloy 7075-T73

1/ Not for use in oxygen systems.

PIN: The PIN consists of prefix "AN" the specification sheet number, a dash number for pipe size, and material code letter. Unassigned PIN's shall not be used.

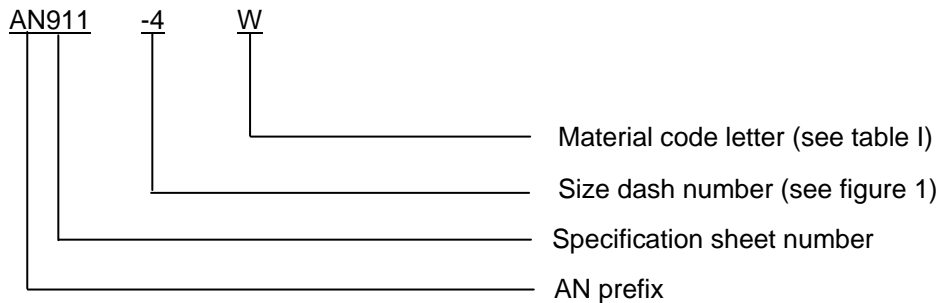

PIN example: AN911-4W indicates a pipe nipple, .500 inch (12.70 mm), aluminum alloy 7075-T73.

Supersession data:

Due to stress corrosion cracking aluminum alloys 2014 and 2024 "D" designator has been replaced by aluminum alloy 7075 "W" designator. Example: AN911-8D use AN911-8W.

Metal cracking due to high temperatures CRES alloy 347 "S" designator has been replaced by CRES alloy 321 "R" designator. Example: AN911-8S use AN911-8R.

Marking: Part shall be permanently marked with the AN PIN, and include the manufacturers CAGE, name, or trademark.

Table II provides a detailed cross-reference of cancelled AN911 PINs and replacement SAE-AS4860 PINs. Users are cautioned to evaluate replacements for their particular application.

CAUTION: The superseding information is valid as of the date of this specification and may be superseded by subsequent revisions of the superseding document.

AN911 Rev 10

TABLE II. Cross-reference data.

AN PIN (inactive)	Pipe size	Replacement AS PIN (for new design)	Replacement AN PIN (inactive)
AN911-1	.125	AS4860-01	
AN911-1D	.125	AS4860W01	AN911-1W
AN911-1J	.125	AS4860J01	
AN911-1K	.125	AS4860K01	
AN911-1R	.125	AS4860R01	
AN911-1S	.125	AS4860R01	AN911-1R
AN911-1T	.125	None	
AN911-1W	.125	AS4860W01	
AN911-2	.250	AS4860-02	
AN911-2D	.250	AS4860W02	AN911-2W
AN911-2J	.250	AS4860J02	
AN911-2K	.250	AS4860K02	
AN911-2R	.250	AS4860R02	
AN911-2S	.250	AS4860R02	AN911-2R
AN911-2T	.250	None	
AN911-2W	.250	AS4860W02	
AN911-3	.375	AS4860-03	
AN911-3D	.375	AS4860W03	AN911-3W
AN911-3J	.375	AS4860J03	
AN911-3K	.375	AS4860K03	
AN911-3R	.375	AS4860R03	
AN911-3S	.375	AS4860R03	AN911-3R
AN911-3T	.375	None	
AN911-3W	.375	AS4860W03	
AN911-4	.500	AS4860-04	
AN911-4D	.500	AS4860W04	AN911-4W
AN911-4J	.500	AS4860J04	
AN911-4K	.500	AS4860K04	
AN911-4R	.500	AS4860R04	
AN911-4S	.500	AS4860R04	AN911-4R
AN911-4T	.500	None	
AN911-4W	.500	AS4860W04	

AN911 Rev 10

TABLE II. Cross-reference data - Continued.

AN PIN (inactive)	Pipe size	Replacement AS PIN (for new design)	Replacement AN PIN (inactive)
AN911-6	.750	AS4860-06	
AN911-6D	.750	AS4860W06	AN911-6W
AN911-6J	.750	AS4860J06	
AN911-6K	.750	AS4860K06	
AN911-6R	.750	AS4860R06	
AN911-6S	.750	AS4860R06	AN911-6R
AN911-6T	.750	None	
AN911-6W	.750	AS4860W06	
AN911-8	1.000	AS4860-08	
AN911-8D	1.000	AS4860W08	AN911-8W
AN911-8J	1.000	AS4860J08	
AN911-8K	1.000	AS4860K08	
AN911-8R	1.000	AS4860R08	
AN911-8S	1.000	AS4860R08	AN911-8R
AN911-8T	1.000	None	
AN911-8W	1.000	AS4860W08	
AN911-10	1.250	AS4860-10	
AN911-10D	1.250	AS4860W10	AN911-10
AN911-10J	1.250	AS4860J10	
AN911-10K	1.250	AS4860K10	
AN911-10R	1.250	AS4860R10	
AN911-10S	1.250	AS4860R10	AN911-10R
AN911-10T	1.250	None	
AN911-10W	1.250	AS4860W10	

Changes from previous issues. Marginal notations are not used in this revision to identify changes with respect to the previous issue due to the extent of the changes.

Referenced documents. In addition to SAE-AS4842, this document references the following:

ASME B46.1
SAE-AS4860
SAE-AS5201
SAE-AS71051

AN911 Rev 10

CONCLUDING MATERIAL

Custodians:

Army - AV
Navy - AS
Air Force - 99
DLA - CC

Preparing activity:
DLA - CC

(Project 4730-2011-073)

Review activities:

Navy - MC, SH
Air Force - 71

NOTE: The activities listed above were interested in this document as of the date of this document. Since organizations and responsibilities can change, you should verify the currency of the information above using the ASSIST Online database at <https://assist.daps.dla.mil>.