

INCH-POUND

AN842 Rev 12
w/AMENDMENT 1
21 July 2011

SUPERSEDING
AN842 Rev 12
7 June 2011

DETAIL SPECIFICATION SHEET

ELBOW - PIPE TO HOSE, 90°

Reinstated after 7 June 2011. Inactive for new design.
For new design, use SAE-AS5185.

This specification is approved for use by all Departments and
Agencies of the Department of Defense.

The requirements for acquiring the product described herein shall consist of this specification sheet
and SAE-AS4843/2.

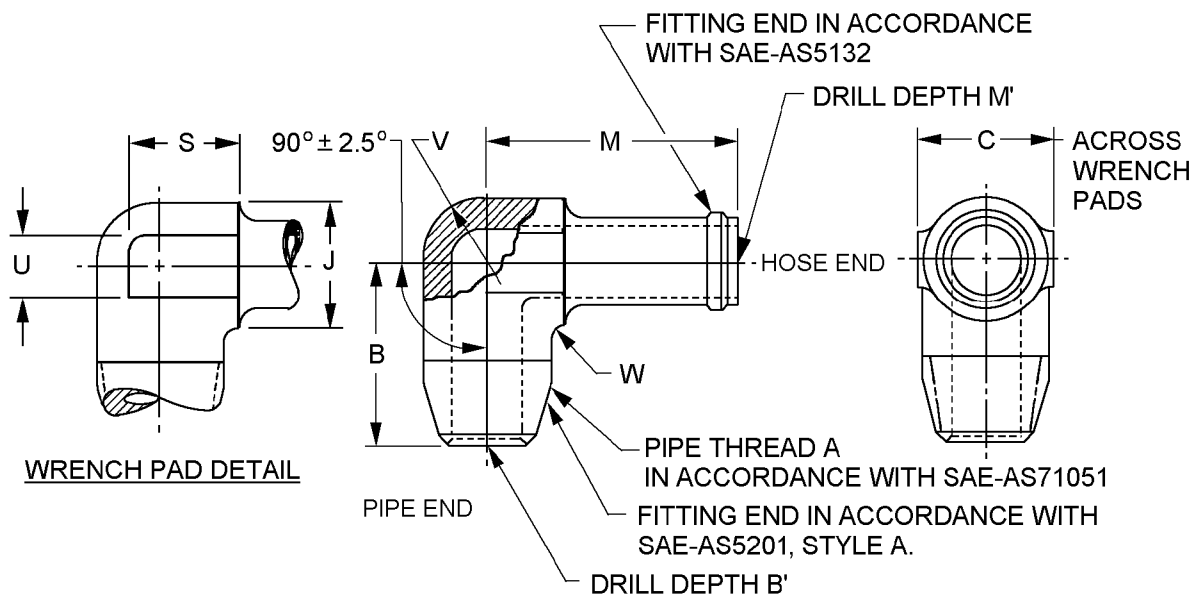

FIGURE 1. 90° elbow dimensions and configuration.

AN842 Rev 12
w/AMENDMENT 1

Dash number	Hose ID inches (mm)	A Pipe thread	B inches (mm) +.047 (1.19) -.000	B' +.047 (1.19) -.000 inches (mm)	C inches (mm)
4	.250 (6.35)	1/8-27 ANPT	.781 (19.84)	.781 (19.84)	.438 (11.13)
6	.375 (9.53)	1/4-18 ANPT	1.094 (27.77)	1.125 (28.58)	.625 (15.88)
8	.500 (12.70)	3/8-18 ANPT	1.188 (30.18)	1.250 (31.75)	.750 (19.05)
10	.625 (15.88)	1/2-14 ANPT	1.484 (37.69)	1.609 (40.87)	.938 (23.83)
12	1.000 (25.40)	3/4-14 ANPT	1.594 (40.49)	1.719 (43.66)	1.125 (28.58)
16	1.000 (25.40)	1-11.5 ANPT	1.594 (40.49)	1.719 (43.66)	1.125 (28.58)
17	1.000 (25.40)	1-11.5 ANPT	1.953 (49.61)	2.078 (52.78)	1.375 (34.93)
20	1.250 (31.75)	1 1/4-11.5 ANPT	2.063 (52.40)	2.188 (55.58)	1.750 (44.45)
21	1.250 (31.75)	1 1/4-11.5 ANPT	2.063 (52.40)	2.188 (55.58)	1.375 (34.93)
24	1.500 (38.10)	1 1/2-11.5 ANPT	2.188 (55.58)	2.313 (58.75)	2.000 (50.80)
25	1.500 (38.10)	1 1/2-11.5 ANPT	2.031 (51.59)	2.297 (58.34)	1.750 (44.45)

Dash number	J dia. inches (mm)	M ±.047 (1.19) inches (mm)	M' .047 (1.19) inches (mm)	S approx inches (mm)	U approx inches (mm)
4	.438 (11.13)	1.718 (43.64)	1.718 (43.64)	.344 (8.74)	.313 (7.95)
6	.578 (14.68)	1.906 (48.41)	1.938 (49.23)	.500 (12.70)	.313 (7.95)
8	.719 (18.26)	1.984 (50.39)	2.047 (51.99)	.625 (15.88)	.438 (11.13)
10	.891 (22.63)	2.172 (55.17)	2.297 (58.34)	.750 (19.05)	.438 (11.13)
12	1.094 (27.79)	2.203 (55.96)	2.328 (59.13)	.938 (23.83)	.500 (12.70)
16	1.094 (27.79)	2.203 (55.96)	2.328 (59.13)	.938 (23.83)	.500 (12.70)
17	1.375 (34.93)	2.344 (59.54)	2.469 (62.71)	1.125 (28.58)	.563 (14.30)
20	1.719 (43.66)	2.516 (63.91)	2.641 (67.08)	1.313 (33.35)	.563 (14.30)
21	1.375 (34.93)	2.344 (59.54)	2.469 (62.71)	1.125 (28.58)	.563 (14.30)
24	1.953 (49.61)	2.641 (67.08)	2.766 (70.26)	1.500 (38.10)	.625 (15.88)
25	1.719 (43.66)	2.641 (67.08)	2.766 (70.26)	1.500 (38.10)	.625 (15.88)

FIGURE 1. 90° elbow dimensions and configuration - Continued.

AN842 Rev 12
w/AMENDMENT 1

Dash number	V radius. inches (mm)	W radius inches (mm)
4	.219 (5.56)	.063 (1.60)
6	.297 (7.54)	.094 (2.39)
8	.359 (9.12)	.094 (2.39)
10	.438 (11.13)	.125 (3.18)
12	.547 (13.89)	.125 (3.18)
16	.547 (13.89)	.125 (3.18)
17	.688 (17.48)	.125 (3.18)
20	.859 (21.82)	.125 (3.18)
21	.688 (17.48)	.125 (3.18)
24	.969 (24.61)	.125 (3.18)
25	.859 (21.82)	.125 (3.18)

NOTES:

1. Dimensions are in inches.
2. Metric equivalents are given for information only.
3. Unless otherwise specified tolerances are ± 0.016 inch (0.41 mm).
4. Break sharp edges and remove all hanging burrs and slivers
5. Machined surfaces shall be finished to 125 μ in Ra, forged surfaces shall be 250 μ inches Ra, unless otherwise specified on the figures. Surface finish shall be in accordance with ASME B46.1.
6. For design features purposes, this standard takes precedence over documents referenced herein.
7. Referenced documents shall be of the issue in effect on date of invitation for bid.

FIGURE 1. 90° elbow dimensions and configuration - Continued.

REQUIREMENTS:

The elbow dimensions and configuration shall be in accordance with figure 1.

Materials and finishes shall be in accordance with SAE-AS4843/2, see table I for material code.

TABLE I. Material and code letters.

Code letter	Material
Blank	Copper alloy
R	Corrosion resistant steel (CRES), Type 321
S	CRES, type 347
T <u>1/</u>	Titanium alloy
W	Aluminum alloy 7075-T73

1/ Not for use in oxygen systems.

AN842 Rev 12
w/AMENDMENT 1

Part or Identifying Number (PIN): The PIN consists of the letter “AN” the specification sheet number, a dash number for pipe and hose size, and a material code for material type. Unassigned PIN’s shall not be used.

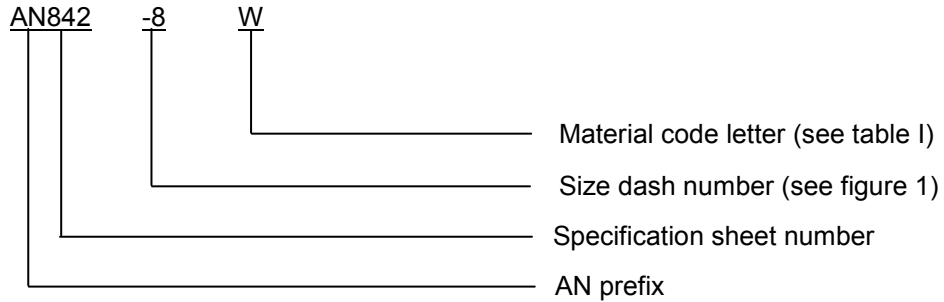

PIN example: AN842-8WP indicates a 90° elbow .500 inch (12.70 mm) hose to .375 inch (9.53 mm) pipe with aluminum alloy 7075-T73.

Supersession data. The aluminum “D” designator has been replaced by the “W” designator.

Marking: Part shall be permanently marked with the AN PIN, and include the manufacturers CAGE, name, or trademark.

Table II provides a detailed cross-reference of AN842 PINs and replacement SAE-AS5185 PINs. Users are cautioned to evaluate replacements for their particular application.

CAUTION: The superseding information is valid as of the date of this specification and may be superseded by subsequent revisions of the superseding document.

AN842 Rev 12
w/AMENDMENT 1TABLE II. Cross-reference data. 1/

AN PIN	Hose Size	Pipe Size	Replacement AS PIN	New design
AN842-4	0.250	0.125	AS5185B0402	
AN842-4D	0.250	0.125	AS5185W0402	AS5185W0402
AN842-4R	0.250	0.125	AS5185R0402	
AN842-4S	0.250	0.125	AS5185R0402	AS5185R0402
AN842-4W	0.250	0.125	AS5185W0402	
AN842-6	0.375	0.250	AS5185B0604	
AN842-6D	0.375	0.250	AS5185W0604	AS5185W0604
AN842-6R	0.375	0.250	AS5185R0604	
AN842-6S	0.375	0.250	AS5185R0604	AS5185R0604
AN842-6W	0.375	0.250	AS5185W0604	
AN842-8	0.500	0.375	AS5185B0806	
AN842-8D	0.500	0.375	AS5185W0806	AS5185W0806
AN842-8R	0.500	0.375	AS5185R0806	
AN842-8S	0.500	0.375	AS5185R0806	AS5185R0806
AN842-8W	0.500	0.375	AS5185W0806	
AN842-10	0.625	0.500	AS5185B1008	
AN842-10D	0.625	0.500	AS5185W1008	AS5185W1008
AN842-10R	0.625	0.500	AS5185R1008	
AN842-10S	0.625	0.500	AS5185R1008	AS5185R1008
AN842-10W	0.625	0.500	AS5185W1008	
AN842-12	0.750	0.750	AS5185B1212	
AN842-12D	0.750	0.750	AS5185W1212	AS5185W1212
AN842-12R	0.750	0.750	AS5185R1212	
AN842-12S	0.750	0.750	AS5185R1212	AS5185W1212
AN842-12W	0.750	0.750	AS5185W1212	
AN842-16	1.000	0.750	AS5185B1612	
AN842-16D	1.000	0.750	AS5185W1612	AS5185W1612
AN842-16R	1.000	0.750	AS5185R1612	
AN842-16S	1.000	0.750	AS5185R1612	AS5185R1612
AN842-16W	1.000	0.750	AS5185W1612	

See note at end of table.

AN842 Rev 12
w/AMENDMENT 1TABLE II. Cross-reference data - Continued. 1/

AN PIN	Hose Size	Pipe Size	Replacement AS PIN	New design
AN842-17	1.000	1.000	AS5185B1616	
AN842-17D	1.000	1.000	AS5185W1616	AS5185W1616
AN842-17R	1.000	1.000	AS5185R1616	
AN842-17S	1.000	1.000	AS5185R1616	AS5185R1616
AN842-17W	1.000	1.000	AS5185W1616	
AN842-20	1.250	1.250	AS5185B2020	
AN842-20D	1.250	1.250	AS5185W2020	AS5185W2020
AN842-20R	1.250	1.250	AS5185R2020	
AN842-20S	1.250	1.250	AS5185R2020	AS5185R2020
AN842-20W	1.250	1.250	AS5185W2020	
AN842-21	1.250	1.000	AS5185B2016	
AN842-21D	1.250	1.000	AS5185W2016	AS5185W2016
AN842-21R	1.250	1.000	AS5185R2016	
AN842-21S	1.250	1.000	AS5185R2016	AS5185R2016
AN842-21W	1.250	1.000	AS5195W2016	
AN842-24	1.500	1.500	AS5185B2424	
AN842-24D	1.500	1.500	AS5185W2424	AS5185W2424
AN842-24R	1.500	1.500	AS5185R2424	
AN842-24S	1.500	1.500	AS5185R2424	AS5185R2424
AN842-24W	1.500	1.500	AS5185W2424	
AN842-25	1.500	1.250	AS5185B2420	
AN842-25D	1.500	1.250	AS5185W2420	AS5185W2420
AN842-25R	1.500	1.250	AS5185R2420	
AN842-25S	1.500	1.250	AS5185R2420	AS5185R2420
AN842-25W	1.500	1.250	AS5185W2420	

1/ For new design use material designator R and W.

Amendment notations. The margins of this specification are marked with vertical lines to indicate modifications generated by this amendment. This was done as a convenience only and the Government assumes no liability whatsoever for any inaccuracies in these notations. Bidders and contractors are cautioned to evaluate the requirements of this document based on the entire content irrespective of the marginal notations.

AN842 Rev 12
w/AMENDMENT 1

Referenced documents. In addition to SAE-AS4843/2, this document references the following:

ASME B46.1
SAE-AS5132
SAE-AS5185
SAE-AS5201
SAE-AS71051

CONCLUDING MATERIAL

Custodians:

Army - AV
Navy - AS
Air Force - 99
DLA - CC

Preparing activity:

DLA - CC

(Project 4730-2011-091)

Review activity:

Air Force - 71

NOTE: The activities listed above were interested in this document as of the date of this document. Since organizations and responsibilities can change, you should verify the currency of the information above using the ASSIST Online database at <https://assist.daps.dla.mil>.