

INCH-POUND

AN800 Rev 6
4 August 2011
SUPERSEDING
AN800 Rev 5
1 June 1954

DETAIL SPECIFICATION SHEET

CONE, UNION

Inactive for new design after 24 July 1998.

This specification is approved for use by all Departments and Agencies of the Department of Defense.

The requirements for acquiring the product described herein shall consist of this specification sheet and MIL-DTL-6001.

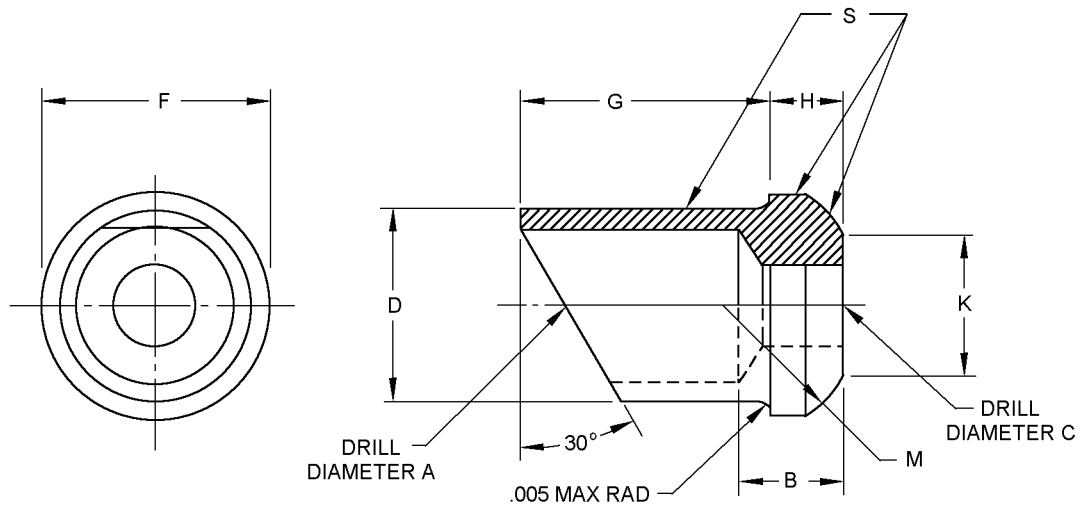

FIGURE 1. Cone, union.

AN800 Rev 6

TABLE I. 1 Dash numbers and size. 1/ 2

Brass	Corrosion resistant steel	Nickel copper alloy	Tube outside diameter	A Diameter	B	C Diameter	D +.000 -.004 Diameter	F +.000 -.004 Diameter	G	H	K Diameter	M Spher radius
2	C2	N2	.125	.1285	.156	.076	.165	.265	.375		.125	.141
3			.188	.191		.140	.250	.320	.438	.125	.172	.172
4			.250	.257	.188	.157	.312	.375	.500		.203	.203
5			.312	.323	.219	.219	.375	.437	.594	.156	.266	.266
6			.375	.386	.281	.281	.469	.547	.719		.328	.328
8			.500	.516	.250	.406	.594	.672	.906	.188	.453	.422
10			.625	.641	.281	.531	.715	.844	1.031	.219	.594	.562

TABLE I. 2 Dash numbers and size – Continued. 1/ 2

Brass	Corrosion resistant steel	Nickel copper alloy	Tube outside diameter	A Diameter	B	C Diameter	D +.000 -.102 Diameter	F +.000 -.102 Diameter	G	H	K Diameter	M Spher radius
2	C2	N2	3.175	3.264	3.962	1.930	4.191	6.731	9.525		3.175	3.581
3			4.775	4.851		3.556	6.350	8.128	11.125	3.175	4.369	4.369
4			6.350	6.528	4.775	3.988	7.925	9.525	12.70		5.156	5.156
5			7.925	8.204	5.563	5.563	9.525	11.100	15.088	3.962	6.756	6.756
6			9.525	9.804		7.137	11.913	13.894	18.263		8.331	8.331
8			12.700	13.106	6.350	10.312	15.088	17.069	23.012	4.775	11.506	10.719
10			15.875	16.281	7.137	13.487	18.161	21.438	26.187	5.563	15.088	14.275

1/ Dimensions are in inches

2/ Metric equivalents are given for information only.

AN800 Rev 6

REQUIREMENTS

Dimensions. See table I. Unless otherwise specified tolerances on decimals are ± 0.010 , angles $\pm 0.5^\circ$.

Configuration. See figure 1. Surfaces "S" must run true with each other within .002 full indicator measurement.

Inactive for new design. Dash numbers 12 and 16 are inactive for new design.

Dash numbers 2, 3 and 4 are inactive for new design except for use in oxygen systems and engine primer lines.

Dash numbers 5, 6, 8 and 10 are inactive for new design and are not to be used on engine primer lines.

Materials: Brass; bars, shapes or forgings.
Corrosion – resistant steel; bars, shapes or forgings.
Nickel copper alloy; bars, shapes or forgings.
See procurement specification.

Finish: See procurement specification.

Identification of product. Add P before the dash number for cadmium – plated brass cones and for cadmium – plated nickel copper alloy cones.

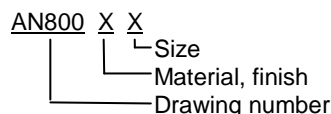

Example of Part or Identifying Number (PIN):

AN800-2 cone – union, brass, for .125 tubing OD.

AN800P2 cone – union, brass, cadmium plated, for .125 tubing OD.

AN800C2 cone – union, corrosion resistant steel, for .125 tubing OD.

AN800N2 cone – union, nickel copper alloy, for .125 tubing OD.

AN800PC2 cone – union, nickel copper alloy, cadmium plated, for .125 tubing OD.

Workmanship. Break all sharp edges and remove all hanging burrs and slivers which might become dislodged under usage.

Changes from previous issue. Marginal notations are not used in this revision to identify changes with respect to the previous issue due to the extent of the changes.

Referenced documents. This document references MIL-DTL-6001.

CONCLUDING MATERIAL

Custodians:
Army – AR
Navy – SH
Air Force - 99
DLA - CC

Preparing activity:
DLA - CC

(Project 4730-2010-184)

Review activities:
Army – AT, AV, CR4
Navy – AS, CG, MC, SA, YD
Air Force - 71

NOTE: The activities listed above were interested in this document as of the date of this document. Since organizations and responsibilities can change, you should verify the currency of the information above using the ASSIST Online database at <https://assist.daps.dla.mil>.