

AN565
 REVISION 7
 13 MARCH 1996
 SUPERSEDING
 AN565
 REVISION 6
 15 MAY 1994

AIR FORCE - NAVY AERONAUTICAL STANDARD

SETSCREW-HEXAGON AND FLUTED SOCKET, HEADLESS

NOTE: THIS DRAWING WAS APPROVED BY JOINT ACTION OF THE AIR FORCE AND NAVY DEPARTMENTS AS THE AIR FORCE-NAVY STANDARD FOR THIS PRODUCT. THIS DRAWING SUPERSEDES ALL ANTECEDENT STANDARD DRAWINGS FOR THE SAME PRODUCT AND SHALL BECOME EFFECTIVE FOR THE PROCUREMENT OF AERONAUTICAL SUPPLIES, OR FOR USE IN NEW DESIGN NOT LATER THAN 6 MONTHS AFTER THE LATEST DATE OF APPROVAL SHOWN.

NOTICE: WHEN GOVERNMENT DRAWINGS, SPECIFICATIONS OR OTHER DATA ARE USED FOR ANY PURPOSE OTHER THAN IN CONNECTION WITH A DEFINITELY RELATED GOVERNMENT PROCUREMENT OPERATION, THE UNITED STATES GOVERNMENT THEREBY INCURS NO RESPONSIBILITY, NOR ANY OBLIGATION WHATSOEVER; AND THE FACT THAT THE GOVERNMENT MAY HAVE FORMULATED, FURNISHED, OR IN ANY WAY SUPPLIED THE SAID DRAWINGS, SPECIFICATIONS, OR ANY OTHER DATA IS NOT TO BE REGARDED BY IMPLICATION OR OTHERWISE AS IN ANY MANNER LICENSING THE HOLDER OR ANY OTHER PERSON OR CORPORATION, OR CONVEYING ANY RIGHTS OR PERMISSION TO MANUFACTURE, USE, OR SELL ANY PATENTED INVENTION THAT MAY IN ANY WAY BE RELATED THERETO.

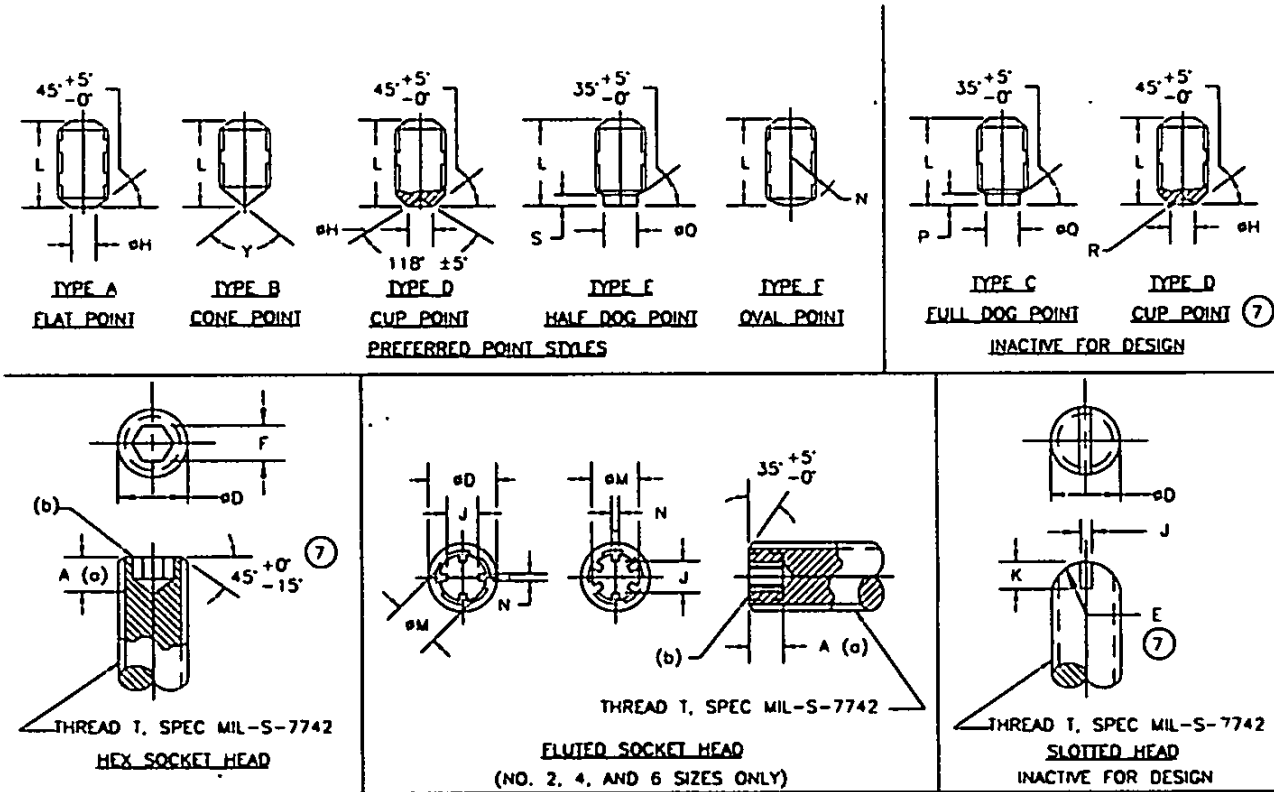

NOM SIZE	THREAD T	ØD MAX	NUMBER OF FLUTES	FLUTED SOCKET HEAD					
				J		M		N	
				SOCKET DIAMETER, MINOR		SOCKET DIAMETER, MAJOR		SOCKET LAND WIDTH	
				MAX	MIN	MAX	MIN	MAX	MIN
NO. 2	NO. 2-56UNC-3A	.086	4	.038	.0375	.050	.049	.017	.016
NO. 4	NO. 4-40UNC-3A	.112	6	.051	.050	.062	.061	.014	.013
NO. 6	NO. 6-32UNC-3A	.138	4	.056	.055	.079	.078	.023	.022

NO'S 2 AND 6 ARE INACTIVE FOR NEW DESIGN AFTER 15 MAY 1994

⑦ DENOTES CHANGE(S)

ANS65
REVISION 7

NOM SIZE	THREAD (7)	ØD MAX	HEX SOCKET HEAD			SLOTTED HEAD			TYPES A AND D		R SPHER RAD	TYPE B Y		TYPES E AND C				TYPE F N RAD (d)
			F (7)		E RAD (7)	J NOM	K NOM	ØH		118° ±2' FOR LENGTHS AND UNDER		90° ±2' FOR LENGTHS AND OVER	Q (7)		S NOM (7)	P NOM (7)		
			MAX	MIN				MAX	MIN		MAX		MIN	MAX			MIN	
NO.2	NO.2-56UNC-3A	.086	.0355	.0350	.052	.018	.022	.047	.039	.031	3/32	7/64	.057	.053	.022	.044	.064	
NO.3	NO.3-48UNC-3A	.099	.0510	.0500	.060	.018	.025	.054	.045	.037	7/64	1/8	.066	.062	.025	.050	.074	
NO.4	NO.4-40UNC-3A	.112	.0510	.0500	.067	.020	.028	.061	.051	.040	1/8	5/32	.075	.070	.028	.056	.084	
NO.5	NO.5-40UNC-3A	.125	.0635	.0625	.075	.023	.031	.067	.057	.045	1/8	3/16	.083	.078	.030	.060	.094	
NO.6	NO.6-32UNC-3A	.138	.0635	.0625	.083	.025	.031	.074	.064	.045	1/8	3/16	.092	.087	.035	.070	.104	
NO.8	NO.8-32UNC-3A	.164	.0791	.0781	.099	.029	.041	.087	.076	.050	3/16	1/4	.109	.103	.040	.080	.123	
NO.10	NO.10-24UNC-3A	.190	.0952	.0937	.114	.032	.048	.102	.088	.060	3/16	1/4	.127	.120	.045	.090	.142	
NO.10	NO.10-32UNF-3A	.190	.0952	.0937	.114	.032	.048	.102	.088	.060	3/16	1/4	.127	.120	.045	.090	.142	
1/4	1/4-20UNC-3A	.250	.1270	.1250	.151	.045	.063	.132	.118	.060	1/4	5/16	.156	.149	.063	.126	.188	
1/4	1/4-28UNF-3A	.250	.1270	.1250	.151	.045	.063	.132	.118	.060	1/4	5/16	.156	.149	.063	.126	.188	
5/16	5/16-18UNC-3A	.3125	.1587	.1562	.188	.051	.078	.172	.156	.060	5/16	3/8	.203	.195	.078	.156	.234	
5/16	5/16-24UNF-3A	.3125	.1587	.1562	.188	.051	.078	.172	.156	.060	5/16	3/8	.203	.195	.078	.156	.234	
3/8	3/8-16UNC-3A	.375	.1900	.1875	.226	.064	.094	.212	.194	.060	3/8	7/16	.250	.241	.094	.188	.281	
3/8	3/8-24UNF-3A	.375	.1900	.1875	.226	.064	.094	.212	.194	.060	3/8	7/16	.250	.241	.094	.188	.281	
1/2	1/2-13UNC-3A	.500	.2530	.2500	.301	.081	.125	.291	.270	.060	1/2	9/16	.344	.334	.125	.250	.375	
1/2	1/2-20UNF-3A	.500	.2530	.2500	.301	.081	.125	.291	.270	.060	1/2	9/16	.344	.334	.125	.250	.375	

THE NO.2 SIZE IS NON-PREFERRED FOR AIRFRAME USE

NO.3-48, NO.5-40, NO.10-24, 1/4-20, 5/16-18, 3/8-16, AND 1/2-13 COARSE THREAD SETSCREWS INACTIVE FOR NEW DESIGN AFTER 1 JULY 1954

NO.4-1 IS INACTIVE FOR NEW DESIGN AFTER 15 MAY 1994

L LENGTH	TOLERANCE	DASH NUMBERS										
		NO. 2-56	NO. 3-48	NO. 4-40	NO. 5-40	NO. 6-32	NO. 8-32	NO. 10-24	1/4-20	5/16-18	3/8-16	1/2-13
1/16	±.010	2-1	3-2	4-2								
1/8	±.010	2-2	3-2	4-2		6-2	8-2					
3/16	±.010	2-3	3-3	4-3	5-3	6-3	8-3	10-3	416-3			
1/4	±.010	2-4	3-4	4-4	5-4	6-4	8-4	10-4	416-4	516-4		
5/16	±.010	2-5	3-5	4-5	5-5	6-5	8-5	10-5	416-5	516-5		
3/8	±.010			4-6	5-6	6-6	8-6	10-6	416-6	516-6	616-6	
7/16	±.010			4-7	5-7	6-7	8-7	10-7				
1/2	±.010			4-8		6-8	8-8	10-8	416-8	516-8	616-8	816-8
9/16	±.010			4-9		6-9	8-9	10-9				
5/8	±.010			4-10		6-10	8-10	10-10	416-10	516-10	616-10	816-10
3/4	±.020					6-12	8-12	10-12	416-12	516-12	616-12	816-12
7/8	±.020					6-14	8-14		416-14	516-14	616-14	816-14
1	±.020						8-16		416-16	516-16	616-16	816-16
1-1/4	±.020								416-20	516-20	616-20	816-20
1-1/2	±.020								416-24	516-24	616-24	816-24
1-3/4	±.020									516-28	616-28	816-28
2	±.020									516-32	616-32	816-32
2-1/4	±.030											816-36
2-1/2	±.030											816-40
2-3/4	±.030											816-44
3	±.030											816-48

AN565
REVISION 7

FINE THREADS

L LENGTH	DASH NUMBERS				
	NO. 10-32	1/4-28	5/16-24	3/8-24	1/2-20
1/8 ±.010	1032-2				
3/16 ±.010	1032-3	428-3			
1/4 ±.010	1032-4	428-4	524-4		
5/16 ±.010	1032-5	428-5	524-5		
3/8 ±.010	1032-6	428-6	524-6	624-6	820-6
7/16 ±.010	1032-7	428-7	⑦ 524-7		
1/2 ±.010	1032-8	428-8	524-8	624-8	820-8
9/16 ±.010	1032-9	428-9			
5/8 ±.010	1032-10	428-10	524-10	624-10	820-10
⑦ 3/4 ±.020	1032-12	428-12	524-12	624-12	820-12
7/8 ±.020		428-14	524-14	624-14	820-14
⑦ 1 ±.020	1032-16	428-16	524-16	624-16	820-16
1-1/4 ±.020	1032-20	428-20	524-20	624-20	820-20
⑦ 1-1/2 ±.020		428-24	524-24	624-24	820-24
1-3/4 ±.020			524-28	624-28	820-28
2 ±.020			524-32	624-32	820-32
⑦ 2-1/4 ±.030					
2-1/2 ±.030					820-40
2-3/4 ±.030					
3 ±.030					820-48

- (o) SOCKET DEPTH A: THE DEPTH OF SOCKET SHALL BE AS GREAT AS PRACTICABLE BUT VARYING CONDITIONS RENDER IT INADVISABLE TO SPECIFY DEFINITE VALUES FOR THIS DIMENSION.
- (b) SOCKET END OF SCREW SHALL BE FLAT AND CHAMFERED. THE CHAMFER SHALL EXTEND TO THE BOTTOM OF THE THREAD AND THE EDGE BETWEEN FLAT AND CHAMFER SHALL BE SLIGHTLY ROUNDED. THE CHAMFER FOR UNC THREADS 0.250 INCH AND LARGER SHALL BE AT THE OPTION OF THE MANUFACTURER, BUT THE ANGLE
⑦ SHALL NOT EXCEED 45°.
- (c) NO. 3-48, 5-40, 10-24, 1/4-20, 5/16-18, 3/8-16, 1/2-13 SETSCREWS INACTIVE FOR NEW DESIGN AFTER 1 JULY 1954.
⑦ SLOTTED HEAD SETSCREWS INACTIVE FOR NEW DESIGN AFTER 1 JULY 1954. USE HEXAGON SOCKET SETSCREWS. NO. 2, AND 6 SIZES FLUTED SOCKET HEAD SETSCREWS ARE INACTIVE FOR NEW DESIGN AFTER 15 MAY 1994.
- (d) TOLERANCES FOR OVAL POINT RADIUS SHALL BE +.015 -.000 FOR NOMINAL SIZES NO. 2 THRU NO. 5 AND
⑦ +.031 -.000 FOR NOMINAL SIZES NO. 6 AND LARGER.

REQUIREMENTS:

- MATERIAL:** STEEL IN ACCORDANCE WITH THE PROCUREMENT SPECIFICATION.
CORROSION RESISTANT STEEL IN ACCORDANCE WITH THE PROCUREMENT SPECIFICATION.
- FINISH:** STEEL - CADMIUM PLATE, SPECIFICATION OO-P-416, TYPE II, CLASS 2. PARTS WITH CLASS 3 PLATING MAY BE FURNISHED FROM SUPPLIER'S STOCK UNTIL 1 JANUARY 1975.
CRES - PASSIVATE IN ACCORDANCE WITH OO-P-35.
- HEXAGON SOCKET AND FLUTED SOCKET SETSCREWS MAY BE SPECIFIED WITH ANY POINT STYLE SHOWN: KNURLED POINT ON TYPE D SETSCREW MAY BE SUPPLIED AS OPTIONAL.

AN565
REVISION 74. CODES:

- ADD POINT STYLE TYPE BEFORE FIRST DASH NUMBER.
- ADD H BETWEEN DASH NUMBERS FOR SETSCREW WITH HEXAGON SOCKET HEAD.
- ADD L BETWEEN DASH NUMBERS FOR SETSCREW WITH FLUTED SOCKET HEAD. (NO. 2, 4 AND 6 SIZES, ONLY.)
- (c) DASH BETWEEN DASH NUMBERS DESIGNATES SLOTTED HEAD SETSCREW (INACTIVE FOR DESIGN).
- ADD C AFTER POINT STYLE TYPE TO DESIGNATE CORROSION RESISTING STEEL SETSCREWS.

5. PART NUMBERS:

EXAMPLES OF PART NOS.:

- AN565B10J2H12 = SETSCREW WITH TYPE B POINT, WITH HEXAGON SOCKET HEAD, NO.10-32 SIZE (.190 INCH DIA)
3/4 (12/16) IN. LONG STEEL.
- AN565B4L5 = SETSCREW WITH TYPE B POINT, WITH FLUTED SOCKET HEAD, NO.4-40 SIZE (.112 INCH DIA),
5/16 INCH LONG, STEEL.
- (c) AN565A10-12 = SETSCREW WITH TYPE A POINT, WITH SLOTTED HEAD, NO. 10-24 SIZE (.190 INCH DIA),
3/4(12/16) INCH LONG, STEEL. (INACTIVE FOR DESIGN).
- AN565BC10J2H12 = SETSCREW WITH TYPE B POINT, WITH HEXAGON SOCKET HEAD, NO.10-32 SIZE, 3/4 INCH
LONG, CORROSION RESISTING STEEL.

- ⑦ 6. THE LIST OF SETSCREWS THAT ARE CONSIDERED AS STANDARD STOCK ITEMS IS INCLUDED IN SPECIFICATION FF-S-200.
7. SCREWS WITH NATIONAL CLASS 3 THREAD MAY BE SUBSTITUTED FOR UNIFIED CLASS 3A THREADS UNTIL EXISTING STOCKS OF NATIONAL CLASS 3 SCREWS ARE DEPLETED. UNIFIED CLASS 3A WILL BE MANDATORY ON ALL SCREWS SUPPLIED AFTER 1 JANUARY 1956.
- ⑦ 8. PARTS MANUFACTURED PRIOR TO THIS REVISION, DATED 15 JANUARY 1996, MAY BE FURNISHED UNTIL EXHAUSTED.

NOTES:

1. DIMENSIONS IN INCHES. UNLESS OTHERWISE SPECIFIED, TOLERANCES: FRACTIONS $\pm 1/64$, DECIMALS $\pm .005$.
2. IN THE EVENT OF A CONFLICT BETWEEN THE TEXT OF THIS DOCUMENT AND THE REFERENCES CITED HEREIN, THE TEXT OF THIS DOCUMENT SHALL TAKE PRECEDENCE.
3. UNLESS OTHERWISE SPECIFIED, ISSUES OF REFERENCED DOCUMENTS ARE THOSE IN EFFECT AT THE TIME OF SOLICITATION.
- ⑦ 4. DIMENSIONS ARE IN ACCORDANCE WITH ASME Y14.5M-1994.
5. PROCUREMENT SPECIFICATION: FF-S-200.
6. SUPERSEDES: USAF DRAWINGS 565 AND 566.

PREPARING ACTIVITY
DLA-IS

(PROJECT: 5305-2118)